



# Leon County Rights-of-Way Manual

---

**Leon County Public Works Department**

**6/19/2018**

This document is to provide guidance for the utility work to be performed within Leon County Rights-of-Way or areas to be dedicated to Leon County.

“People Focused. Performance Driven.”

## Table of Contents

<b>CHAPTER I Overview .....</b>	<b>4</b>
1.1.0 Intent and Purpose.....	4
1.2.0 Applicability .....	4
1.3.0 General .....	5
1.4.0 Existing Policies and Procedures.....	6
1.5.0 Leon County Facility Construction Permit .....	6
1.6.0 Leon County Right-of-Way Placement Permit .....	6
1.7.0 Minimum Material Standards and Specifications .....	6
1.8.0 Construction Standards and Specifications .....	6
1.9.0 Appeals.....	6
1.10.0 Enforcement .....	7
1.11.0 Performance Bonds .....	9
1.12.0 Maintenance Bonds .....	9
1.13.0 Definitions.....	10
<b>CHAPTER II Water and Sewer Agreement .....</b>	<b>16</b>
2.1.0 Water and Sewer Agreement.....	16
<b>CHAPTER III Authorized Water or Sewer Service Areas.....</b>	<b>17</b>
3.1.0 Jurisdiction .....	17
3.2.0 General .....	17
3.3.0 Determination of Water and Sewer Service Provider.....	18
3.4.0 Applying for an Authorized Water or Sewer Service Areas.....	18
3.5.0 Nature of Authorized Water and Sewer Service Areas .....	18
3.6.0 Application Procedure .....	19
<b>Chapter IV Water and Sewer Standards and Specifications .....</b>	<b>22</b>
4.1.0 Applicability .....	22
4.2.0 Water Distribution .....	22
4.3.0 Sewer Force Main Distribution .....	26
4.4.0 Gravity Sewer Distribution .....	28
4.5.0 Fittings .....	29
4.6.0 Valves and Other Mechanical Components.....	31
4.7.0 Testing.....	34
<b>Chapter V Facility Construction Permits.....</b>	<b>35</b>
5.1.0 General .....	35

5.2.0	Permitting Requirements .....	35
<b>CHAPTER VI</b>	<b>Right-of-way Placement Permit.....</b>	<b>38</b>
6.1.0	Right-of-Way Placement License.....	38
6.2.0	Registration.....	39
6.3.0	General .....	40
6.4.0	Right-of-way Placement Permit .....	40
6.5.0	Coordination with Other Utilities.....	41
6.6.0	Proper Corridor for Placements .....	42
6.7.0	Existing Drainage Structures .....	42
6.8.0	Removal and relocation of Facilities from the Right-of-Way .....	42
6.9.0	Duration of the Right-of Way Placement Permit .....	43
6.10.0	Performance Bond.....	43
6.11.0	Material Specifications and Construction Standards .....	44
6.12.0	Unauthorized Placement .....	44
6.13.0	Enforcement .....	44
6.14.0	Permittee Liability .....	44
6.15.0	Non-compliance with Placement Permit .....	44
<b>Chapter VII</b>	<b>Construction Standards and Specifications .....</b>	<b>48</b>
7.1.0	Construction Coordination with the Department .....	48
7.2.0	Non-compliance with Facilities Construction Permit .....	50
7.3.0	Non-compliance with Right-of-Way Placement Permit.....	50
7.4.0	Traffic Control .....	51
7.5.0	Excavation-Pipe Installation-Backfilling.....	54
7.6.0	Jack and Bore.....	60
7.7.0	Directional Bore .....	62
7.8.0	Casings.....	64
7.9.0	Codes and Standards .....	64
7.10.0	Road Restoration.....	65
7.11.0	Surface Preparation.....	65
7.12.0	Asphalt Patch .....	66
7.13.0	Manhole Openings and Other Appurtenances.....	66
7.14.0	Unpaved Roads.....	67
	When unpaved roads or any portion of a right-of-way is cut, the cut area must be compacted back to obtain equal or greater density of the adjacent undisturbed soils. .....	67

7.15.0	Final Dressing.....	67
7.16.0	Grassing and Mulching.....	67
7.17.0	Sodding .....	67
7.18.0	Seeding .....	68
7.19.0	Mulching .....	68
7.20.0	Hydro-Seeding.....	68
7.21.0	Record Drawings .....	69

# **CHAPTER I**

## **Overview**

### **1.1.0 Intent and Purpose**

1.1.1 It is the intent of the County to promote the public health, safety and general welfare by adopting and administering reasonable rules, regulations, policies and procedures not inconsistent with State and federal law.

1.1.2 The purpose of this document is to provide rules, regulations, policies and procedures for the placement, construction, and maintenance of Utilities and Communications Facilities within the Rights-of-way of Leon County. This document:

- a. Outlines Leon County policies in regard to enforcement, fees and bonds required to construct or place Utilities and Communications Facilities within the Rights-of-way of Leon County;
- b. Outlines the procedure to obtain a License or to register with Leon County pursuant to Chapter 16, Leon County Code of Laws;
- c. Outlines the procedure to obtain an Authorized Water or Sewer Service Area and to construct, own, operate, or expand a Water System or Sewage Disposal System within the unincorporated area of Leon County pursuant to Chapter 18, Leon County Code of Laws;
- d. Outlines Utility construction standards and minimum material Specifications for the construction of Water Systems and Sewage Disposal Systems in the unincorporated area of Leon County;
- e. Outlines the procedure to obtain a Facility Construction Permit or Right-of-way Placement Permit; and
- f. Outlines the construction standards for all work performed within the Right-of-way of Leon County.

1.1.3 This document shall be referred to as the “Leon County ROW Manual.”

1.1.4 Nothing herein shall excuse a Utility Provider, Communications Services Provider or Communications Facility Provider from complying with all applicable local, State, and federal laws and regulations.

1.1.5 The Code of Laws, as amended, shall prevail over the provisions of this Leon County ROW Manual to the extent of any conflict therewith.

### **1.2.0 Applicability**

1.2.1 This Leon County ROW Manual applies to all Persons seeking to construct, maintain, repair, operate, and/or remove lines for the transmission of public Utilities under, on, over, across, or within the Rights-of-way, including but not

limited to gas, power, and television, or as regulated by a franchise, as applicable.

1.2.2 This Leon County ROW Manual applies to all Persons seeking to transmit Communications Services under, on, over, across, or within the Rights-of-way or to construct, place, install, maintain or operate a Communications Facility or Utility Pole under, on, over, across, or within the Rights-of-way, unless otherwise exempt by operation of federal, State or local laws or regulations.

1.2.3 This Leon County ROW Manual applies to all Persons seeking to perform work within the Rights-of-way.

### 1.3.0 **General**

1.3.1 Applications for Permits, Registrations, Licenses, and Authorized Water and Sewer Service Areas shall be submitted to the Department by electronic mail, U.S. mail, or by hand-delivery, with the applicable fee. Payment by credit card (VISA or MasterCard) is the preferred method of payment. The County will accept checks or money orders, payable to Leon County, Florida, when payment by credit card is not possible. For frequent applicants, pre-authorized credit cards may be held on file to accelerate the Permit process.

1.3.2 If a Permit application package is submitted to the Department by U.S. mail or hand-delivery, one (1) copy of this permit application with two (2) sets of the physically signed and sealed engineering documents, including the Plans and drawings, must be provided, except that a Facility Construction Permit request shall be submitted with four (4) sets of the proposed construction Plans. If a Permit application package is submitted by electronic mail, the engineering documents, including the Plans, must be electronically or digitally signed and digitally sealed in compliance with Chapter 61G15-23 of the Florida Administrative Code. The Plans shall be in accordance with the Leon County Code of Laws and this Leon County ROW Manual.

1.3.3 The Permittee shall be in possession of Permit, as applicable, prior to construction and shall have the Permit posted at the construction site during construction.

1.3.4 The Permittee, upon receiving a Facilities Construction Permit or Right-of-Way Placement Permit, is authorized to perform only the work outlined in the Permit application and attachments, and any conditions prescribed by the Department or FDEP. The Permittee, while in the process of accomplishing the permitted activity, shall follow and perform all requirements promulgated by this Leon County ROW Manual, Chapter 16 and Chapter 18 of the Leon County Code, and all State and federal laws and regulations.

1.3.5 The contractor shall not employ the Engineer of Record as the contractor's Engineer of Record or as a specialty engineer.

#### **1.4.0 Existing Policies and Procedures**

The policies, procedures, and Specifications outlined in this Leon County ROW Manual supersede any previous policies, procedures, or guidelines for the construction or expansion of Water Systems or Sewage Disposal Systems in the County, and for the construction or placement of Utilities in the unincorporated area of Leon County or in the Rights-of-way of Leon County.

#### **1.5.0 Leon County Facility Construction Permit**

Any Person who desires to obtain a Leon County Facility Construction Permit to construct or extend a Public Water System or Public Sewage Disposal System within the County is required to follow and conform to those procedures outlined in Chapters III, IV and V of this document.

#### **1.6.0 Leon County Right-of-Way Placement Permit**

Any Person who desires to obtain a Leon County Right-of-way Placement Permit to place or maintain a Utility or a Communications Facility within the Rights-of-way is required to follow and conform to those procedures outlined in Chapter VI of this document.

#### **1.7.0 Minimum Material Standards and Specifications**

Any Person who obtains a Facility Construction Permit or Right-of-way Placement Permit is required to meet minimum material standards set by the local, State and federal agencies and the Specifications as outlined in Chapter VII of this document.

#### **1.8.0 Construction Standards and Specifications**

Any Person who obtains a Facility Construction Permit or Right-of-way Placement Permit is required to follow County approved construction standards as outlined in Chapter VII of this document.

#### **1.9.0 Appeals**

Appeals of decisions shall be as provided in Section 16-110 or Section 18-32(a)(2) of the Leon County Code, as applicable.

## 1.10.0 Enforcement

1.10.1 The Department, following review of the non-compliance, shall be authorized to initiate any or all of the following enforcement procedures:

- a. Penalties as provided in Section 18-329(e), Leon County Code;
- b. Enforcement as provided in Section 16-109, Leon County Code;
- c. Grant an extension period and repeat a follow-up inspection;
- d. Issue a stop work order and revoke the Permit or authorization to construct the facility or perform work within the Right-of-way;
- e. Call on the Performance Bond or Surety for completion of the necessary Corrective Measures; and/or
- f. Perform such Corrective Measures when immediate Corrective Measures are required to prevent possible injury to the public, the cost of which shall be paid by the Permittee prior to being allowed to continue work on any portion of the project.

## 1.10.2 Unauthorized Right-of-Way Placements

- a. The Inspector, upon discovery of an unauthorized placement within the Right-of-way, shall determine the nature of the violation. If the party responsible for the activity cannot demonstrate that the activity is an emergency, the Inspector shall notify the Department.
- b. The Department shall discuss and consider the circumstances and severity of the violation and shall be authorized to take any or all of the following enforcement procedures:
  1. Enforcement measures as provided in Section 1.10.0;
  2. Allow the completion of the activity and officially record the violation accordingly;
  3. Have the Inspector instruct the responsible party of the activity to submit a Right-of-Way Placement Permit application within two (2) days following the violation;
  4. Issue a stop work order and instruct the violator to perform the necessary measures to prevent a hazard to the public and restore the Rights-of-way;



5. Notify the Sheriff's Office and request assistance in resolving the violation; and/or
  6. Impose a fine up to ten (10) times the Permit fee.
- c. When it comes to the attention of the Department that an unauthorized placement has occurred, the Department shall make every attempt to determine the party responsible for the activity and to recover any costs of such actions from the responsible party.
  - d. Nothing herein shall preclude the County from seeking an injunction or other legal relief to obtain compliance with the requirements of the Leon County Code or this Leon County ROW Manual.

### 1.10.3 Stop Work Orders

- a. The construction and operation of permitted facilities shall be discontinued, except for remedial work, when found in violation of County policies and procedures, or if in non-compliance of the permit:
  1. When the Department issues a stop work order, no further work shall be performed from that moment on, except the required work to alleviate the deficiencies and safety hazards. The stop work order shall remain in effect until the Department issues a written authorization to lift the order.
  2. A stop work order shall be posted at the job site.
  3. Upon completion of the required work, the Department shall provide written authorization to proceed with the operation and remove the stop work order, which has been posted at the job site.
  4. If unauthorized construction activities persist at any time after the notification to shut down the operation, the Department shall notify the Permittee and Project Supervisor that they are in violation of the stop work order, and may request the arrest and prosecution thereof if the work persists.
  5. The stop work order is directed not only to the Permittee, but also to the person or firm actually performing the physical labors or the person responsible for the construction or maintenance of the facility in violation of the Permit. Continued work in violation of the stop work order shall be punishable in accordance with Section 1-9, Leon County Code. Each day work is performed in violation of the stop work order is a separate violation.

6. If the required work is not performed within twenty (20) days following the issuance of the stop work order, it shall be determined that the project is incapable of being completed by the Permittee; and the Permit may be revoked and the Performance Bond may be called to complete the project, as determined by the County.

#### **1.11.0 Performance Bonds**

- 1.11.1 Prior to commencing the construction of infrastructure to be dedicated to the County upon completion, the Permittee shall obtain and deliver to the County a Performance Bond in the amount of 110% of the total estimated cost of construction with a Surety approved by the County. The County may waive the requirement for a Performance Bond upon the receipt of other adequate means of assuring the Permittee's ability to perform its obligation under the Permit granted by the County.
- 1.11.2 Prior to commencing any construction pursuant to a Right-of-way Placement Permit for a Utility, the Permittee shall obtain and deliver to the County a Performance Bond in an amount of 100% of the total estimated cost of Right-of-way restoration. The County may waive the requirement for a Performance Bond upon the receipt of other adequate means of assuring the Permittee's ability to perform its obligation under the Permit granted by the County.
- 1.11.3 Prior to the issuance of a Right-of-way Placement Permit for the placement or maintenance of a Communications Facility, the Permittee shall obtain and deliver to the County a Performance bond in accordance with Section 16-113, Leon County Code.
- 1.11.4 The use of the Performance Bond shall not preclude the County from determining a default pursuant to Section 18-32(c), Leon County Code.
- 1.11.5 The County Engineer may require Performance Bonds beyond the requirements set forth herein to ensure compliance with this Leon County ROW Manual or the Code of Laws.

#### **1.12.0 Maintenance Bonds**

- 1.12.1 After completion of the construction of infrastructure to be dedicated to the County and prior to the approval of a plat or replat, the Permittee shall obtain and deliver to the County a Maintenance Bond in the amount of 10% of the total estimated cost of construction with a Surety approved by the County.
- 1.12.2 Any Right-of-Way Placement Permit Permittee who has violated a provision of the Leon County Code or this Leon County ROW Manual during a prior project may be required to obtain and deliver to the County a Maintenance Bond for any subsequently issued Permits.

1.12.3 When a Maintenance Bond is required, it shall be set at an amount or equal to 10% of the total estimated cost of construction, or 100% of the Right-of-way restoration cost, whichever is greater, and shall last a period of two (2) years from the date of final inspection and acceptance.

1.12.4 The County Engineer may require Maintenance Bonds beyond the requirements set forth herein to ensure compliance with this Leon County ROW Manual or the Code of Laws.

#### 1.12.5 **Permittee Liability and Guarantee**

1.12.6 The Permittee is responsible for all construction and work performed within the Right-of-way or on County approved systems as determined by the Permit application and attachments during the actual placement for one (1) full year following the date of final inspection and approval. The Permittee will typically hold a Performance Bond during construction and the period of guarantee.

1.12.7 The Permittee shall not be responsible for damage and/or conditions created by other Persons.

#### 1.13.0 **Definitions**

ANSI: the American National Standard Institute.

ASTM: the American Society for Testing and Materials.

Authorization Holder: a Person that has obtained approval for an Authorized Water or Sewer Service Area.

Authorized Water or Sewer Service Area: a legally described area located within the County in which there exists either an exclusive or non-exclusive sewer and/or water service agreement between a Person and Leon County for the rights and responsibility to construct, operate, and/or maintain a Public Water System and/or a Public Sewage Disposal System.

AWWA: the American Water Works Association.

Board of County Commissioners (Board): the Board of Commissioners of Leon County, Florida.

Casing: a pipe surrounding a carrier pipe and designated to resist potential impacts and carry imposed loads.

City: Tallahassee, Florida, as a geographic location, or Tallahassee, Florida, a Florida municipal corporation, as a legal entity, as indicated by the context used.

Communications Facility: Communications Facility as defined in Section 16-102, Leon County Code.

Communications Services: Communications Services as defined in Section 16-102, Leon County Code.

Communications Services Provider: Communications Services Provider as defined in Section 16-102, Leon County Code.

Comprehensive Plan: the Tallahassee-Leon County 2030 Comprehensive Plan, as amended.

Conduit: an enclosure for protecting a Utility (e.g., wires, cables, or pipes).

Corrective Measures: a task or action required to correct a deficiency.

County or Leon County: Leon County, Florida, as a geographic location, or Leon County, Florida, a charter county and political subdivision of the State of Florida, as a legal entity, as indicated by the context used.

County Administrator: the chief administrative officer of the county, or the county administrator's designee. The term County Administrator also includes his or her designee.

County Engineer: the licensed engineer designated by the Board of County Commissioners to furnish engineering assistance for the administration of these regulations. The term County Engineer also includes his or her designee.

Culvert: any structure not classified as a bridge or casing which provides an opening under a roadway.

Day(s): for purposes of computing any period of time expressed in day(s), the day of the act, event or default from which the designated period of time begins to run shall not be included and the last day of the period so computed shall be included unless it is a Saturday, Sunday, or legal holiday, in which event the period shall run until the end of the next day which is neither a Saturday, Sunday, or legal holiday.

Default: conditions set forth in Section 18-32, Leon County Code, which conveys to the County the right to enter upon the premises of a system; possess, keep and maintain all system records; and transfer the system to County ownership.

Department: the Leon County Department of Public Works.

Engineer: a professional engineer licensed in the State of Florida.

Engineer of Record: the Professional Engineer or Engineering Firm registered in the State of Florida that develops the criteria and concept for the project, performs the analysis, and is responsible for the preparation of the Plans and Specifications.

Exclusive Authorized Service Area: an Authorized Water Service Area granted to one Person, to the exclusion of any other Persons.

Facility Construction Permit: a Permit authorizing the construction of a Public Water System and/or a Public Sewage Disposal System or the expansion of a previously permitted and constructed system and/or the placement of such facilities within the Rights-of-way.

FDEP: Florida Department of Environmental Protection.

Florida Building Code: the Florida Building Code promulgated under Chapter 553, F.S., including the Leon County amendments thereto, as both may be amended.

Grace Period: a specified time established by the Inspector, which will allow the Permittee to delay the performance of Corrective Measures necessary to address deficiencies found in the permitted construction operations, typically not to exceed 72 hours.

Inspector: an authorized representative of the Leon County Public Works Department who acts within the scope of the duties assigned to ascertain that construction and restoration is in accordance with the approved Permit application, conditions of the Permit, County policies and procedures, and the health, safety and welfare of the public.

Leon County Code: the Code of Laws of Leon County, Florida, as amended from time to time.

License: an initial authorization or renewal thereof issued by the County, whether such authorization is designated as a franchise, Permit, license, resolution, contract, certificate, agreement, or otherwise, which authorizes the occupation and use of the Rights-of-way for Utilities.

Maintenance Bond: the financial guarantee of the completed construction or Utility placement for a period of time to be determined by the County Engineer following the approval of the final inspection.

Pass-through Provider: Pass-through Provider as defined in Section 16-102, Leon County Code.

**Performance Bond:** the financial guarantee of the proper performance of the requirements of the Leon County Code, this Leon County ROW Manual, the Permit, and other County policies and procedures, including but not limited to the guarantee of site restoration.

**Permit:** the authorization issued by the County that must be obtained before a Person may construct, place, install or maintain Utilities, Communications Facilities, or other structures within the Rights-of-way or construct a Public Water System or Public Sewage Disposal System and shall include, but not be limited to, a Facility Construction Permit and a Right-of-way Placement Permit.

**Permittee:** the Permit applicant or holder and authorized agent of the Permit applicant or holder.

**Person:** any natural person or corporation, business association or other business entity, including, but not limited to a partnership, a sole proprietorship, a governmental entity, a public or private agency of any kind, a Utility Provider, a successor or assign of any of the foregoing or any other legal entity.

**Plans:** drawings, including reproductions thereof, showing the location, character, dimensions, and details of the work to be accomplished.

**Project Supervisor:** a person experienced in the type of work being performed and who has the authority to represent the Permittee in a routine decision making capacity concerning the manner and method of carrying out the work authorized by Permit.

**Public Rights-of-way or Rights-of-way** means land in which the County owns the fee or has an easement devoted to or required for use as a Transportation Facility and may lawfully grant access pursuant to applicable law, and includes the surface, the air space over the surface and the area below the surface of such rights-of-way. For the purposes of this definition, Transportation Facility means any means for the transportation of people or property from place to place which is constructed, operated, or maintained in whole or in part from public funds. The terms Public Rights-of-way or Rights-of-way shall not include: (1) City, State, or federal rights-of-way unless the County has been properly delegated authority to issue Permits for structures within those rights-of-way, unless prohibited by State or federal law; or (2) platted utility easements that are not part of a dedicated public rights-of-way.

**Public Sewage Disposal System:** any Sewage Disposal System within the County serving more than eight (8) residential, commercial, or industrial units.

**Public Water System:** any Water System within the County serving more than eight (8) residential, commercial, or industrial units.

**Record Drawings:** a set of drawings in a format as specified by the County

Engineer submitted upon completion of a project reflecting all deviations from the Permit, and showing the exact dimensions, geometry and location of all elements of the work completed under the Permit.

Registration or Register: Registration or Register as defined in Section 16-102, Leon County Code.

Right-of-way Placement Permit: a Permit authorizing the construction and/or placement of a Utility, Communications Facility, or other structure or facility within the Rights-of-way.

Roadbed: that portion of the Right-of-way occupied by the subgrade and supporting Shoulder material.

Road Surface: the portion of the roadway providing for the movement of vehicles, exclusive of shoulders, consisting of edge of pavement to edge of pavement.

Sewage Disposal System: any plant, system, facility or property used or useful or having the present capacity for future use in connection with the collection, treatment, purification or disposal of sewage, and, without limiting the generality of the foregoing definition, shall embrace treatment plants, pumping stations, intercepting sewers, pressure lines, mains, and all necessary appurtenances and equipment and shall include all property, rights, easements and franchises relating to any such system and deemed necessary or convenient for the operation thereof. The term "sewage disposal system" shall also include all sanitary sewers within the County and shall embrace sewer mains and laterals for the reception of sewage from premises connected therewith and for carrying such sewage to some part of the sewage disposal system.

Shoulders: that portion of the right-of-way outside the edges of the traveled way extending to the top of the front slopes. The Shoulders may either be paved or unpaved.

Specifications: the directions, provisions, casting work plans, and all stipulations contained in the plans or in the Permit setting out or relating to the method and manner of performing work, or the quantities and qualities of materials and labor to be provided under the Permit.

State: either Florida, as a geographic location, or the State of Florida, as a legal entity.

Substantial Change: a substantial deviation from the approved Plans that results in a conflict with other Utility structures, a hazard to public health, safety, or welfare, or does not conform to County or Permit Specifications, or, in the opinion of the Inspector, a change that warrants review and approval by the Department.

Surety: the Person that agrees to become responsible and liable by executing, as surety, a Performance Bond or Maintenance Bond and who guarantees the faithful performance of the Performance Bond.

Total Estimated Cost of Construction: the pre-determined total estimated cost of the project excluding those costs incurred from engineering, legal, and land acquisition.

Utility: electric, gas, water, sewer, television, or other essential services provided to the public at large.

Utility Pole: a pole or similar structure used in whole or in part to provide Communications Services or electric distribution, lighting, traffic control or similar function. Street signs shall not be considered a Utility Pole for the purposes of this Leon County ROW Manual.

Utility Provider: any Person that is an electric, gas, water, sewer or other public Utility, and who owns or operates appurtenant facilities or equipment for transmission of such Utility's goods, commodities or services. This term does not include a Communications Services Provider, Wireless Infrastructure Provider, or Pass-through Provider.

Water System: Any plant, wells, pipes, tanks, reservoirs, system, facility or property used or useful or having the present capacity for future use in connection with the obtaining and supplying water for human consumption, fire protection, irrigation, consumption by business, or consumption by industry, and, without limiting the generality of the foregoing definition, shall embrace all necessary appurtenances and equipment and shall include all property, rights, easements and franchises relating to any such system and deemed necessary or convenient for the operation thereof. The term "water system" shall also include all water pipes or lines, valves, meters and other water-supplying equipment within the County and shall embrace water mains and laterals for the carrying of water to the premises connected therewith and for carrying such water from some part of the water supply system.

Wireless Infrastructure Provider: Wireless Infrastructure Provider as defined in Section 16-102, Leon County Code.



## **CHAPTER II Water and Sewer Agreement**

### **2.1.0 Water and Sewer Agreement**

- 2.1.1 The Water and Sewer Agreement, dated May 10, 2005, as amended, is hereby adopted and incorporated herein (“Water and Sewer Agreement”).
- 2.1.2 The County shall be the sole local governmental entity to authorize the planning, construction and operation of Water Systems and Sewage Disposal Systems within the County.
- 2.1.3 The City is responsible for providing water and/or sewer service to all properties located within its franchise area, except as provided in the Water and Sewer Agreement. The City shall have the exclusive right to manage and operate its Water System and Sewage Disposal System in the unincorporated area of the County, except as provided in the Water and Sewer Agreement.
- 2.1.4 The City water and sewer construction standards, as amended, shall apply to all City water and sewer franchise areas.
- 2.1.5 County standards and Permit procedures apply to the City for any water and/or sewer construction that impact County-maintained facilities, such as roads or drainage facilities.
- 2.1.6 The terms and requirements of the Water and Sewer Agreement shall prevail over the provisions of this Leon County ROW Manual to the extent of any conflict therewith.

## **CHAPTER III**

### **Authorized Water or Sewer Service Areas**

#### **3.1.0 Jurisdiction**

- 3.1.1 The County has invoked the jurisdiction of the Florida Public Service Commission pursuant to Section 367.171, Florida Statutes, by and through Resolution No. 17-12.
- 3.1.2 The Florida Public Service Commission has regulatory authority over all Public Water Systems and Public Sewage Disposal Systems serving or proposing to serve over 100 persons, unless exempt from the jurisdiction of the Florida Public Service Commission, such as the City of Tallahassee, Talquin Electric Cooperative, Inc., and Talquin Water and Wastewater, Inc.
- 3.1.3 The County retains sole regulatory authority over all Public Water Systems and Public Sewage Disposal Systems serving or proposing to serve 100 or less persons but more than eight (8) persons within the County, and those systems exempt from the jurisdiction of the Florida Public Service Commission unless otherwise provided in Chapter 18 of the Leon County Code.
- 3.1.4 The County retains all regulatory authority over the abandonment of any system within the County.

#### **3.2.0 General**

- 3.2.1 Any Person not regulated by the Florida Public Service Commission who desires to construct, operate, or own a Public Water System or Public Sewage Disposal System shall first obtain an Authorized Water or Sewer Service Area by following the application procedure outlined in this Chapter.
- 3.2.2 Any Authorized Holder who desires to expand outside its Authorized Water or Sewer Service Area shall first apply for and receive approval for an amended Authorized Water or Sewer Service Area. The application procedure outlined in Chapter may be used for the purpose of amending the existing Authorized Water or Sewer Service Area.
- 3.2.3 Any Person who desires to construct, operate, or own a Public Water System or Public Sewage Disposal System within the County is required to follow and perform those procedures outlined in this Leon County ROW Manual or such other regulatory document as may be agreed to between the County and other units of local government.

### **3.3.0 Determination of Water and Sewer Service Provider**

- 3.3.1 It shall be the primary responsibility of the property developer, owner, or other property representative to approach and secure the services of capable water and sewer providers.
- 3.3.2 The Department shall, upon request, assist the property developer, owner, or other property representative in identifying potential water and sewer service providers. The property developer, owner, or other property representative is responsible for negotiating the terms leading to an obligation of the provider(s) to furnish water and sewer service.
- 3.3.3 In the event an agreement cannot be reached to the satisfaction of the property developer, owner, or other property representative and any potential water or sewer service providers identified, or through some alternate source, the development proposal may be re-evaluated to bring the proposed development within the allowances and abilities of both the Comprehensive Plan and the available providers of water and sewer service.
- 3.3.4 Development shall not proceed, in application or otherwise, if a water or sewer service provider has not been established. The use of septic tanks shall only be allowed as provided in the Leon County Land Development Code.

### **3.4.0 Applying for an Authorized Water or Sewer Service Areas**

- 3.4.1 It shall be the responsibility of the selected provider to make application for the particular Authorized Water or Sewer Service Area sought to support of the proposed development.

### **3.5.0 Nature of Authorized Water and Sewer Service Areas**

- 3.5.1 Authorized Water or Sewer Service Areas shall be granted for such time as may be established by the County.
- 3.5.2 Authorized Water or Sewer Service Areas will grant the Public Water System or Public Sewage Disposal System owner the right within a specific geographical area to own, acquire, construct, operate, and maintain the system specified in the authorization.
- 3.5.3 The Authorization Holder shall be required to serve, upon request, any owner, tenant, or occupant on any parcel of land within the Authorized Water or Sewer Service Area adjacent to any publicly dedicated right-of-way or easement wherein a Public Water System or Public Sewage Disposal System is constructed or, pursuant to the terms of the authorization, will be constructed.

3.5.4 Authorized Water or Sewer Service Areas may be made exclusive or non-exclusive upon such reasonable terms and conditions as established by the County.

3.5.5 Acceptance of an Authorized Water or Sewer Service Area by the Authorization Holder conveys to the County, in the event of a default as defined by Chapter 18 of the Leon County Code, the right to enter upon the premises, possess, keep and maintain all system records, operate the system and perform such maintenance and repairs as are necessary to provide the services required by the system. In the event of a default, the County may revoke the Authorized Water or Sewer Service Area from the Authorized Holder after written notice and an opportunity to cure the default. Upon such revocation, the Public Water System or Public Sewage Disposal System shall become the property of the County.

### 3.6.0 **Application Procedure**

3.6.1 Any Person not regulated by the Florida Public Service Commission who desires to obtain an Authorized Water or Sewer Service Area within the unincorporated area of Leon County, or who desires to amend an existing Authorized Water or Sewer Service Area, shall first submit a pre-application, except that the provisions of this Section shall not apply to applications to construct, operate or own a Water System or Sewage Disposal System within the unincorporated area of the County, which rights are granted pursuant to an interlocal agreement with another governmental entity.

3.6.2 The following data shall be submitted with the pre-application:

- a. A boundary description on a copy of the Leon County Property Appraiser's map of the geographical area for which authorization to operate such system is sought.
- b. A copy of the most recent assessment roll of the Leon County Property Appraiser showing the name, address, parcel identification number and description of all property within the area for which the authorization is sought.
- c. Conceptual drawings indicating tentatively the system to be constructed, plant location, location of collection system, and any other general information that will determine when and where services will be supplied within the area described.
- d. Information as to the proposed method of financing the Public Water System or Public Sewage Disposal System for which authorization to construct or operate such system is sought.

3.6.3 Where required by Florida law, a Professional Engineer competent in the area of sanitary engineering (specifically potable water systems and sanitary sewer systems), shall provide the preliminary planning and design of all systems

proposed for the installation on the property to within the required levels of service.

- 3.6.4 Upon the Department receiving a completed pre-application with all of the pertinent data and pre-application fee, the Department shall schedule a public hearing.
- 3.6.5 All property owners listed on the tax rolls within the area for which authorization is sought shall be notified by mail by the Department of such pre-application and the time and place set for the public hearing at least ten (10) days prior to the date of the hearing. The post mark date shall be at least ten (10) days before such hearing.
- 3.6.6 The County shall provide the public notice of the hearing on the pre-application, which shall be published once each week for two (2) successive weeks in a newspaper of general circulation published in the County. The first publication shall be no sooner than twenty (20) days prior to the hearing and in substantially the following form:

NOTICE IS HEREBY GIVEN THAT \_\_\_\_\_  
has applied to the Board of County Commissioners of Leon, County,  
Florida, for the authorization to operate a water/sewage disposal system,  
embracing the follow described lands in Leon County, Florida to-wit:

(Description of area by area map, public road, street, or landmark)

Said Board of County Commissioners will hold a public hearing at  
\_\_\_\_\_ o'clock \_\_.m., on said application in the meeting room of the  
Board of County Commissioners of Leon County, Florida, on the \_\_\_ day  
of \_\_\_\_\_, 20\_\_\_, and all persons affected or interested in such  
application are invited to be present at said time and place to voice their  
approval or disapproval of said application.

Dated this \_\_\_\_ day of \_\_\_\_\_, 20\_\_\_.

\_\_\_\_\_  
Chairman, Board of County Commissioners  
Leon County, Florida

- 3.6.7 Upon the completion of the pre-application procedure and upon receiving approval of the conceptual Plans by the Department, the applicant may proceed to submit an application for an Authorized Water or Sewer Service Area in the area for which the pre-application has been approved or any portion thereof, along with the required application fee.

3.6.8 As part of the application, the applicant shall be required to obtain a Facilities Construction Permit in accordance with the policies and procedures outlined in Chapter V.

3.6.9 The following data shall be submitted with the application.

- a. Legal description of all properties upon which treatment facilities, wells, lift stations, pump stations, or other portions of the Water System or Sewage Disposal System will be located other than mains and lines;
- b. A description of the facilities to be provided, including a construction implementation schedule showing dates upon which the facilities will be constructed in each portion of the geographical area for which authorization is sought;
- c. A set of Plans and Specifications prepared under the direction and supervision of a Professional Engineer, along with a copy of the operating procedures for such system (where applicable);
- d. A list of the proposed rates and fees to be charged to users of the system.
- e. An estimate of operating costs and revenues on an annual basis for the first three (3) years of operation;
- f. An estimate of the total capital requirements of the system and the amount of anticipated indebtedness, terms for repayment of the indebtedness, and the security required thereafter;
- g. Copies of any agreements between the system owner and other persons relating to the construction or operation of the system;
- h. Instruments of transfer in the event the system is to be transferred to the County at the end of the authorization period; and
- i. Such other data as the County may deem appropriate.

3.6.10 Upon the County receiving all of the required application information to the satisfaction of the County Administrator, the County shall process the Facilities Construction Permit application following the procedures outlined in Chapter V.

3.6.11 The applicant's failure to implement the Plans according to the approved construction schedule may lead to default under Section 18-32 of the Leon County Code.

## Chapter IV Water and Sewer Standards and Specifications

### 4.1.0 Applicability

4.1.1 This Chapter shall apply to all water and sewer projects within Leon County that are not within the City of Tallahassee or Talquin Electric Cooperative, Inc. franchise areas as identified in “Appendix B – Franchises”, as amended.

4.1.2 All work associated with water and sewer projects completed within the City of Tallahassee or Talquin Electric Cooperative, Inc. franchise areas shall be completed using the approved Specifications of that entity.

### 4.2.0 Water Distribution

#### 4.2.1 Polyvinyl Chloride (PVC) Pipe

a. *Material Requirements.* All PVC pressure piping shall conform to National Sanitation Foundation (NSF) requirements. All PVC piping shall be less than six (6) months in age based on the manufacturer date as identified on the piping.

1. *Small PVC pressure piping.* PVC pressure pipe smaller than 4 inch nominal diameter shall be Schedule 80 PVC in accordance with ASTM D1785. Schedule 80 pipe shall have either solvent welded or threaded joints. PVC pressure pipe shall bear the approval seal of the NSF.

PVC solvent cement shall be in compliance with ASTM D2564 and in accordance with the pipe manufacturer's recommendations. Lubricant for Schedule 80 threaded joints shall be Teflon tape only.

Socket type, solvent welded fittings for Schedule 80 PVC pipe shall be in conformance with ASTM D2467. Threaded type fittings for Schedule 80 PVC pipe shall be in conformance with ASTM D2464. All solvent welded or threaded joints shall be watertight.

2. *Large PVC pressure piping.* PVC pressure pipe 4 inch nominal diameter and greater shall conform to the latest version of AWWA C900 and shall have standard Dimensional Ratio (DR) of DR-18 and a pressure class of 235 psi per AWWA C900-07 [150 psi per AWWA C900-97/Factory Mutual (FM) 1612].

Pipe joints shall be made with integral bell and spigot pipe ends. The bell shall consist of an integral thickened wall section designed to be at least as strong as the pipe wall. The bell shall be supplied with factory glued rubber ring gasket that meets the requirements of ASTM F477.

Pipe using push-on joints shall be in strict accordance with AWWA C111 and ANSI A21.11. Push-on joints shall be made in strict accordance with manufacturer's instructions. Push-on joints shall conform to ASTM D3139 and gaskets shall conform to ASTM F477.

Lubricant, if required, shall be an inert, non-toxic, water soluble compound incapable of harboring, supporting, or culturing bacterial life.

- b. *Installation Requirements.* Excavation, drilling and boring shall be in accordance with Sections 7.5.0, 7.6.0, and 7.7.0 of Chapter 7. Bedding material for PVC force main shall be in accordance with Section 7.5.12 of Chapter 7. All PVC pipe shall be laid in accordance with the pipe manufacturer's published installation guide, the AWWA Manual M23 and the Uni-Bell Plastic Pipe Association installation recommendations. PVC pipe for below ground installation shall be supplied in nominal lengths no greater than 20 feet.

1. *Small PVC pressure piping.* (smaller than 4 inch nominal diameter), all threaded and solvent welded joints shall be made watertight in accordance with ASTM D2855, ASTM D2564, and AWWA Manual M23. All pipe cutting, threading, and jointing procedures for threaded and solvent welded PVC pipe joints shall be in accordance with pipe and fitting manufacturer's printed installation instructions.

Flanges for Schedule 80 PVC pipe shall be rated for a 150 psi working pressure with ANSI B16.1 dimensions and bolting pattern. Flanges shall be connected to PVC piping with either solvent welded or threaded joints in accordance with ASTM D2467 or ASTM 2464, respectively. At threaded joints between PVC and metal pipes, the metal side must contain the socket end and the PVC side the spigot.

Gaskets shall be neoprene, full faced type with a minimum thickness of 1/8 inch. Nuts and bolts shall be hexagonal with machine threads, manufactured of Type 316 stainless steel in accordance with ASTM A320, Class 2. Type 316 stainless steel flat washers w/lock washers shall be used against PVC flanges.

2. *Large PVC pressure piping.* (4 inch nominal diameter and greater), the bell and spigot joint shall be assembled in accordance with the pipe manufacturer's installation instructions, ASTM D2774, and AWWA Manual M23.



#### 4.2.2 Ductile Iron Pipe

- a. *Material Requirements.* All piping and fittings shall be new and unused, no refurbished piping or fittings shall be accepted. All ductile iron pipes shall be designed in accordance with the latest version of ANSI A21.50 and AWWA C150, and meeting the mechanical properties as specified in ANSI A21.51 and AWWA C151. Pipe shall have a minimum rated water working pressure of 150 psi and shall be furnished in laying lengths of 20 feet or less.

The minimum thickness class for underground pipe shall be Pressure Class 150. Flanged pipe shall have a minimum thickness of Class 50.

- b. *Coating and Linings.* Outside coating shall be an asphaltic coating with a minimum of 1 mil thick. Ductile iron pipe and fittings to be installed aboveground shall be furnished with a shop applied epoxy primer to a thickness of 5 mils and a top coat of epoxy to a minimum thickness of 15 mils, on the exterior. Ductile iron pipe shall be cement-mortar lined per ANSI/AWWA C104/A21.4.

- c. *Installation Requirements.*

1. Excavation, drilling and boring shall be in accordance with Sections 7.5.0, 7.6.0, and 7.7.0 of Chapter 7. Bedding shall be in accordance with Section 7.35.12 of Chapter 7. Ductile iron pipe and fittings shall be installed in accordance with the requirements of ANSI/AWWA C600 and AWWA Manual M41. Ductile iron pipe for below ground installation shall be supplied in nominal lengths no greater than 20 feet.
2. Cutting shall be done in accordance with approved methods stated in the Ductile Iron Pipe Research Association's "Installation Guide for Ductile Iron Pipe", leaving a smooth cut at right angles to the axis of the pipe. Cut ends and rough edges shall be ground smooth. For push-on or mechanical joints, cut pipe shall be beveled and de-burred.

#### 4.2.3 High Density Polyethylene (HDPE) Pipe

- a. *Material Requirements.* HDPE pipe shall be furnished in standard laying lengths not to exceed 50 feet and no shorter than 20 feet.

1. *Small diameter piping:* HDPE piping smaller than 4 inch nominal diameter shall conform to AWWA C901 and ASTM D3035 and have minimal working pressure of 160 psi at 73.4 degrees meeting the requirements of SDR 11.
2. *Large diameter piping:* HDPE piping for nominal diameters of 4 inches and larger shall conform to AWWA C906 and ASTM D3035 and have

minimal working pressure of 160 psi at 73.4 degrees meeting the requirements of SDR 11.

- b. *Installation Requirements.* HDPE shall be installed in accordance with the manufacturer's instructions. HDPE shall be installed either by open trench construction or directional bore method.
  - 1. Excavation, drilling and boring shall be in accordance with Sections 7.5.0, 7.6.0, and 7.7.0 of Chapter 7. Bedding shall be in accordance with Section 7.5.12 of Chapter 7.
  - 2. The pipe shall be joined with butt, heat fusion joints as outlined in ASTM D2657 and conform to the Generic Butt Fusion Joining Procedure for Field Joining of Polyethylene Pipe, Technical Report TR-33/2005, published by the Plastic Pipe Institute (PPI).
  - 3. All transition from HDPE pipe to ductile iron pipe or PVC pipe shall be a molded flange connector adapter within a carbon steel back-up ring assembly. Ductile iron back-up rings shall mate with cast iron flanges per ANSI B16.1. A 316 stainless steel back-up ring shall mate with a 316 stainless steel flange per ANSI B16.1.

#### 4.2.4 Service Connections

- a. New service lines shall be 1 inch in size from the tap to the meter box location. Service piping shall be 1 inch HDPE conforming to ASTM-3035 or Schedule 80 PVC in accordance with ASTM D1785 with minimum working pressure of 160 psi.
- b. New service taps on water main shall have a minimum 7/8 inch (opening cut) in the saddle clamp. The saddle clamp shall be double strap, nylon saddle with stainless steel straps, with cc tap. Single strap clamps will not be accepted. New service taps shall be located no closer than 18 inches to the existing taps on the main.
- c. Corporation stop shall be 1 inch minimum, bronze with Mueller cc threads and compression joint outlet, or approved equal.
- d. Service lines shall have a minimum of 36 inch cover in the roadway areas and 36 inch cover in the ditches.

#### 4.2.5 Flushing and Disinfection

- a. Distribution and transmission system piping, valves, and appurtenances shall be totally flushed and cleaned prior to final acceptance. Flushing velocity shall be a minimum of 2.5 fps. All water generated during flushing shall be discharged or disposed of in a manner meeting all State and federal regulations.
- b. Prior to be placed into service, all potable water system piping, valve and appurtenances shall be chlorinated in accordance with AWWA C651. All potable water piping, fitting, valves, and appurtenances shall be disinfected with a chlorine solution with a sufficient concentration such that the initial chlorine concentration in the water line shall be a minimum of 50 mg/l available chlorine, at any point in the line.
- c. Chlorine used for the purpose of disinfection shall be high test granular calcium hypochlorite which contains approximately 65 to 70 percent available chlorine by weight. Water service lines shall be disinfected in a similar manner as that for water mains. Chlorine solution shall remain in the water lines for no less than 24 hours, unless directed by the engineer. After 24 hours, the free residual chlorine concentration in the water line at the pipe extremities shall be at least 10 mg/l. If not, the water line shall be re-disinfected.

#### 4.3.0 Sewer Force Main Distribution

##### 4.3.1 Polyvinyl Chloride (PVC) Pipe

- a. *Material Requirements.* PVC pressure piping for sewer force main shall have nominal diameters of 4 inches or greater and shall conform to the requirements of the Nation Institute of Standards and Technology (NIST) PS 22-70, with Standard Dimensional Ratio of DR-18 for both the barrel and bell, and shall be pressure rated at 100. PVC pressure pipe shall be of the bell and ring type integral bell or gasket coupling conforming to the requirements of AWWA C905.

Pipe joints shall be made with integral bell and spigot pipe ends. The bell shall consist of an integral thickened wall section designed to be at least as strong as the pipe wall. The bell shall be supplied with factory glued rubber ring gasket that meets the requirements of ASTM F477.

- b. *Installation Requirements.* Excavation, drilling and boring shall be in accordance with Sections 7.3.0, 7.4.0, and 7.5.0 of Chapter 7. Bedding material for PVC force main shall be in accordance with Section 7.3.12 of Chapter 7. All PVC pipe shall be laid in accordance with the pipe

manufacturer's published installation guide, the AWWA Manual M23 and the Uni-Bell Plastic Pipe Association installation recommendations.

The bell and spigot joint shall be assembled in accordance with the pipe manufacturer's installation instructions, ASTM D2774, and AWWA Manual M23.

#### 4.3.2 Ductile Iron Pipe

- a. *Material Requirements.* All piping and fittings shall be new and unused, no refurbished piping or fittings will be accepted. All ductile iron pipes shall be designed in accordance with the latest version of ANSI A21.50 and AWWA C150, and meeting the mechanical properties as specified in ANSI A21.51 and AWWA C151. Pipe shall have a minimum rated water working pressure of 150 psi and shall be furnished in laying lengths of 20 feet or less.

The minimum thickness class for underground pipe shall be Pressure Class 150. Flanged pipe shall have a minimum thickness of Class 50.

b. *Coating and Lining.*

1. For sanitary sewer applications, line the interior surface of all ductile iron pipe and fittings to a minimum thickness of 40 mils (DFT) with a high solids (97% minimum) coal-tar free ceramic epoxy.
2. For buried applications, coat the exterior surface of all buried fittings with a 1.0 mil thick asphaltic coating in accordance with ANSI A21.51.
3. For exposed or above-ground applications, coat the exterior surface with an epoxy primer to a thickness of 5 mils and apply a top coat of epoxy to a minimum thickness of 15 mils.

c. *Installation Requirements.*

1. Excavation, drilling and boring shall be in accordance with Sections 7.5.0, 7.6.0, and 7.7.0 of Chapter 7. Bedding shall be in accordance with Section 7.5.12 of Chapter 7. Ductile iron pipe and fittings shall be installed in accordance with the requirements of ANSI/AWWA C600 and AWWA Manual M41. Ductile iron pipe for below ground installation shall be supplied in nominal lengths no greater than 20 feet.
2. Cutting shall be done in accordance with approved methods stated in the Ductile Iron Pipe Research Association's "Installation Guide for Ductile Iron Pipe", leaving a smooth cut at right angles to the axis of the pipe. Cut ends and rough edges shall be ground smooth. For push-on or mechanical joints, cut pipe shall be beveled and de-burred.

3. Fittings for ductile iron pipe shall be flanged joint with a minimum working pressure of 150 psi. All ductile iron fittings shall be manufactured in accordance with ANSI/AWWA C110/A21.10 or C153/A21.53.

#### 4.3.3 High Density Polyethylene (HDPE) Pipe

- a. *Material Requirements.* HDPE pipe is an approved material for all 4 inch to 12 inch installation of sanitary sewer collection system components. HDPE pipe shall be manufactured using PE4710 resin and shall conform to the latest version of AWWA C906 and ASTM D3035 and have a minimal working pressure of 160 psi at 73.4 degrees meeting the requirements of DR 11.
- b. *Installation Requirements.*

1. Excavation, drilling and boring shall be in accordance with Sections 7.5.0, 7.6.0, and 7.7.0 of Chapter 7. Bedding shall be in accordance with Section 7.5.12 of Chapter 7. HDPE shall be installed in accordance with the manufacturer's instructions. HDPE shall be installed either by open trench construction or directional bore method.
2. The pipe shall be joined with butt, heat fusion joints as outlined in ASTM D2657 and conform to the Generic Butt Fusion Joining Procedure for Field Joining of Polyethylene Pipe, Technical Report TR-33/2005, published by the Plastic Pipe Institute (PPI).
3. All transition from HDPE pipe to ductile iron or PVC shall be a molded flange connector adapter within a carbon steel back-up ring assembly. Ductile iron back-up rings shall mate with cast iron flanges per ANSI B16.1. A 316 stainless steel back-up ring shall mate with a 316 stainless steel flange per ASNI B16.1.

#### 4.4.0 Gravity Sewer Distribution

- 4.4.1 *Material Requirements.* PVC pipe is an approved material for 4 inch through 15 inch pipe installations, HDPE pipe is an approved material for 4 inch through 12 inch pipe installations, and Ductile Iron pipe is an approved material for 4 inches and larger pipe installations.

- a. *Polyvinyl Chloride (PVC) Pipe.* All PVC sewer pipe shall be manufactured from extra strength polyvinyl chloride pipe conforming to ASTM D3034, and shall meet or exceed the requirements of ASTM D1784, Type 1, Grade 1 (12454-B). Standard PVC pipe for gravity sewer applications shall be DR-26. Thick-wall PVC for installation depths greater than 16 feet shall be C-900,

DR-18. PVC sewer pipe shall be supplied in nominal standard laying lengths no greater than 20 feet.

- b. *Ductile Iron Pipe.* All ductile iron pipes shall be designed in accordance with the latest version of ANSI/AWWA C150/A21.50 for a rated water working pressure which is adequate for the rated working pressure plus a surge allowance of 100 psi, using a 2-to-1 factor of safety on the sum of working pressure plus surge allowance. The minimum thickness class for underground pipe shall be Pressure Class 150. Ductile Iron pipe shall be manufactured in accordance with the latest revision of ANSI/AWWA C151/A21.51.
- c. *High Density Polyethylene (HDPE) Pipe.* All HDPE pipe shall be manufactured using PE4710 resin and shall conform to the latest version of AWWA C906. HDPE pipe for gravity sewer applications shall be iron pipe size (IPS) with a wall-thickness dimension ration (DR) of 17, and a minimum pressure rating of 125 PSI.

4.4.2 *Installation Requirements.* PVC and HDPE gravity sewer lines shall be laid according to applicable portions of ASTM D2321. Ductile iron pipe shall be installed in accordance with the requirements of Section VII of the Handbook of Ductile Iron Pipes. The laying of the sewer pipe shall be commenced at the lowest point, with all bell ends upstream.

#### 4.5.0 **Fittings**

##### 4.5.1 Thrust Restraints and Blocks

- a. Restraining gaskets and/or mechanical thrust restraints shall be used to provide resistance to thrust forces generated in pressurized pipelines at all valves, bends, tees, reducers, and caps or plugs.
- b. When restrained joints are required for below ground installations, restrained joint pipe and/or mechanical joint restraints shall be provided. Except for PVC Push-on joint restraints, split-design mechanical thrust restraints shall only be considered for adding restraint to existing ductile iron and PVC pipes. Bolts and nuts for mechanically restrained joints shall be hot dipped galvanized, low alloy, high-strength steel. All-thread rods and associated washers and nuts for restrained joints shall be Type 304 Stainless Steel.
- c. All plugs, caps, tees, and bends of force lines shall be provided with thrust blocks, restraint joints, or other approved thrust restraint method.

#### 4.5.2 Flanged Fittings

- a. All distribution, collection and transmission pipe fittings for installation above ground shall be flanged joint type ductile iron fittings and shall be Class 125 per ANSI B16.1 with a minimum working pressure of 150 psi. All ductile iron fittings shall be manufactured in accordance with ANSI/AWWA C110/A21.10 or C153/A21.53.
- b. Flange gaskets shall be full-face, 1/8 inch thick, cloth-inserted rubber and shall be suitable for a water pressure of 150 psi at a temperature of 150°F.
- c. Bolts and nuts for flanges located indoors, in enclosed vaults, in structures, and outdoors aboveground shall be carbon steel, ASTM A307, Grade B. Bolts and nuts for buried and submerged flanges and flanges located below grade in open vaults and structures shall be Type 316 stainless steel conforming to ASTM A193, Grade B&M for bolts and ASTM A194, Grade 8M for nuts.

#### 4.5.3 Mechanical Fittings

- a. All distribution and transmission pipe fittings for installation below ground shall be mechanical joint type ductile iron fittings. All ductile iron fittings shall be manufactured in accordance with ANSI/AWWA C110/A21.10 or C153/A21.53. Materials assembly and bolting shall be in strict accordance with ANSI/AWWA C111 and ANSI/AWWA C153. Tee head bolts and nuts for mechanical joints shall be manufactured of CORTEN, high strength, low alloy, corrosion resistance steel.
- b. Rubber gasket joints for mechanical joint type ductile iron fitting shall conform to ANSI/AWWA C111/A21.11.

#### 4.5.4 Flexible Expansion Joints

- a. *Ductile Iron.* Flexible expansion joints manufactured of ductile iron shall conform to the material requirements of ASTM A536 and ANSI/AWWA C153/A21.53. Each flexible expansion joint shall be pressure tested against its own restraint to a minimum of 350 psi (250 psi for flexible expansion joints 2 inches in diameter or 30 inches in diameter and larger). A minimum 2:1 safety factor shall apply.

Each flexible expansion joint shall consist of an expansion joint designed and cast as an integral part of a ball and socket type flexible joint, having a minimum per ball deflection of 20°, 2 inches to 12 inches; 15°, 14 inches to 36 inches; 12°, 48 inches and 4 inch minimum exposure.

- b. *Rubber.* Rubber expansion joints shall be molded wide double arch design manufactured of neoprene rubber with polyester and steel reinforcement.

Neoprene body shall be supplied with a Hypalon coating. Joints shall be flanged suitable for 150 psi water working pressure in accordance with ANSI B16.1 dimensions and bolting patterns.

#### 4.6.0 Valves and Other Mechanical Components

4.6.1 *General.* For potable water and reclaimed water source, all brass and bronze components shall be designed and manufactured in accordance with AWWA C800. Metal surfaces in contact with potable water shall be "lead free" and conform to NSF 372. A component that may come into contact with potable water shall meet both NSF 61 and 372.

#### 4.6.2 Gate Valves

- a. Valves for distribution and transmission system pressure piping 4 inches and larger shall be cast iron or ductile iron body and bonnet, resilient wedge gate type valves with a water service pressure rating of 250 psi. All valves shall be manufactured to meet the requirements of AWWA C509 (cast iron) or AWWA C515 (ductile iron).
- b. The valve wedge shall be constructed of ductile iron and shall be fully encapsulated with a resilient EPDM rubber and provided with male type guides and polymer guide covers.
- c. Buried valves shall have non-rising stems and a 2 inch square operating nut. For valves 4 inches through 12 inches, the operating nut shall attach directly to the valve stem. For valves 14 inches and greater, the operating nut shall operate a spur gear or bevel gear actuator to open and close the gate. Valves shall open by turning counter-clockwise (left) with arrow cast in metal to indicate direction of opening.
- d. Valve stems shall be copper/bronze or manganese/bronze alloy and shall be sealed by at least three O-rings with two of the O-rings located above the thrust collar. The thrust collar shall have upper and lower thrust washers to reduce friction and minimize operating torque.
- e. All internal and external ferrous surfaces of the valve body and bonnet shall have fusion-bonded epoxy coating, complying with ANSI/AWWA C550. Epoxy coating for potable water system valves shall be certified to NSF/ANSI Standard 61/372.
- f. Each valve shall be tested to a hydrostatic pressure of 350 psi.



#### 4.6.3 Check Valves

- a. Check valves shall be the rubber flapper swing check type, designed to minimize slamming during the rapid reversal of flow in the piping system. All check valves shall fully comply with all provisions of AWWA C508 and shall be rated for a cold working pressure of 250 psi. All internal check valve components shall be capable of being replaced without removing the valve body from the piping system.
- b. The check valve shall be ductile iron meeting ASTM A536, Gr. 65-45-12. The check valve seating component shall be mounted at a 45-degree angle to the centerline of the pipe with a full flow opening equivalent to the pipe flow area. The valve disc shall be Buna-N rubber encapsulated steel disc flapper with a maximum swing opening angle (disk stroke) of 35-degrees. The check valve body exterior and interior shall be coated with fusion-bonded epoxy. For potable water applications, the interior epoxy surface in contact with water shall be NSF-61/372 approved. For sewage applications, all exposed bolts for mounting and maintenance shall be stainless steel.
- c. The check valve shall be equipped with a visual disk positing indicator.

#### 4.6.4 PVC Valves

- a. *Ball valves.* All PVC ball valves ½ inch through 4 inches in size shall be of one piece capsule type manufactured of Type 1, Grade 1 PVC. Ball valves shall be true union design with two-way blocking capability and shall have solvent welded socket or NPT threaded ends. Ball valves shall have Teflon seats with Viton backing cushions and Viton O-ring seals, and shall be designed for a 150 psi water working pressure at 120°F. Valves shall be supplied with ABS lever operating handles.
- b. *Ball check valves.* All PVC ball check valves ½ inch through 4 inches in size shall be of a solid thermoplastic construction manufactured of Type 1, Grade 1 PVC. Ball valves shall be true union design with solvent welded socket or NPT threaded ends. Ball check valves shall be furnished with a solid thermoplastic ball and stainless steel spring to assist ball in seating faster. Ball check valves shall have Teflon seats with Viton. The same seal shall function as both the ball seat and the union seal. The ball check valve shall be designed for a 150 psi water working pressure at 120°F.

#### 4.6.5 Corporation Stops

- a. Except for HDPE water mains, all water service taps shall be made using a brass or bronze quarter-turn ball-type valve at the connection to the main.

- b. For 1<sup>1</sup>/<sub>2</sub> inch or 2 inch services a 2 inch square operating nut shall be provided and installed with a valve box.
- c. For services on HDPE water mains, the corporation stop shall be an integrated valve contained within the electro-fusion tapping tee.

#### 4.6.6 Air Release Valves

- a. Combination air valves for sewage and effluent (non-public access reclaimed water) applications shall be specifically designed to operate with liquids carrying solid particles. The combination air valve shall be made with a composite body and select corrosion-resistant polymer and stainless steel internal operating parts. The combination air valve shall be rated for a working pressure range of 3 PSI to 150 PSI, with a test pressure rating of 250 PSI.
- b. Combination air valves for potable and reclaimed water (public access) applications shall be specifically designed to operate with clean liquids (no solid particles). The combination air valve shall be made with an epoxy-coated ductile iron body and select corrosion-resistant polymer and stainless steel internal operating parts. The combination air valve shall be rate for a working pressure range of -3 PSI to 285 PSI. All valves shall be NSF 61/372 approved for potable water applications.

#### 4.6.7 Valve Boxes

##### a. *Material Requirements.*

1. An adjustable two-piece screw-type asphalt-dipped cast iron valve box and heavy-duty drop-in lid rated for HS-25 loading shall be provided for all valves larger than 1 inch. Valve boxes in high traffic areas shall have a drop-in lid with an extra-deep 4 inch skirt.
2. All distribution and transmission system valves larger than 1 inch shall be installed with a two-piece adjustable cast iron valve box and lid. The castings shall be manufactured of clean, even grain, gray cast iron conforming to ASTM A48, Class 30B for Gray Iron Castings.
3. The valve boxes shall be coated inside and outside with an asphaltic coating prior to machining, so that the machined seating surfaces will be free of any coating.

##### b. *Installation Requirements.*

1. Valve boxes and lids shall be installed so as not to transmit shock or stress to the valve or pipe. Valve boxes will be centered on the operating nut and plumb with the finished surface.

2. For valves located in roadways that will be paved, the top of the valve boxes shall have a minimum of one foot of cover. After the roadway is paved, contractor shall raise valve boxes flush with pavement. The cut for raising the valve boxes shall be two feet square, the soil compacted to existing road standards, and the valve boxes encased in asphalt a minimum of six inches thick.
3. For valve boxes located in areas other than roadways, the valve boxes shall be flush with the existing terrain and encased in force concrete collars (3,000 psi), two feet square and six inches thick.

#### 4.7.0 Testing

4.7.1 A pressure piping test shall be performed prior to final inspection. The testing shall be performed in the presence of the Inspector, and the Inspector shall be notified in accordance with Section 7.1.3 of Chapter VII.

#### 4.7.2 Water and Sewer Force Main Hydrostatic Testing

- a. After the pipe is laid and flushed, the system shall be hydrostatically tested in accordance with AWWA Standard C600 for ductile iron pipe, AWWA Standard C605 for PVC pipes, and ASTM F2164 for HDPE piping. The Inspector is to be present during the examination.

#### 4.7.3 Gravity Sewer Low Pressure Testing

- a. Generally, the sewers will be tested from manhole to manhole or from manhole to the end of the sewer if there is no manhole at the end. Service connections along the sewer main will be included in the testing.
- b. After the pipe is laid and flushed, the system shall be tested using a low-pressure air test in accordance with ASTM C924 for ductile iron piping and ASTM F1417 for PVC and HDPE piping.
- c. An infiltration/exfiltration test will only be allowed when site conditions and circumstances demonstrate that the test would evaluate the structural integrity of the system more effectively than the low-pressure examination. Department approval is required and the test procedure will be outlined by the Department. Maximum allowable infiltration/exfiltration shall be less than 100 gallons per day per inch diameter per pipe mile.

## **Chapter V Facility Construction Permits**

### **5.1.0 General**

- 5.1.1 Any Authorized Holder who desires to construct or extend a Public Water System or a Public Sewage Disposal System shall first acquire a Facilities Construction Permit from the Department, except that the provisions of this Chapter shall not apply to Authorized Holders governed by an interlocal agreement (i.e. City of Tallahassee). An Authorized Holder who desires to replace or upgrade an existing system located within the Rights-of-way shall be required to obtain a Right-of-way Placement Permit in accordance with Chapter VI.
- 5.1.2 Routine Taps and Minor Maintenance Repairs on existing Public Water Systems and/or Public Sewage Disposal Systems shall be exempt from having to obtain a Facilities Construction Permit but shall be required to obtain a Right-of-way Placement Permit in accordance with Chapter VI when such work affects the Roadbed.
- 5.1.3 As used in this Chapter, the term *Minor Maintenance Repairs* shall mean any repairs to the well and/or associated appurtenances, and repairs to a wastewater treatment facility, or any repairs to the distribution/collection system involving three or less continuous joints of pipe.
- 5.1.4 As used in this Chapter, the term *Routine Taps* shall mean a normal service connection between a service customer and a readily accessible and adjacent water main or sewer main.

### **5.2.0 Permitting Requirements**

- 5.2.1 An Authorization Holder who desires to construct a Public Water System or a Public Sewage Disposal System shall submit a letter to the Department requesting a Facility Construction Permit and must identify the project, location, and Utility, along with four (4) copies of the signed and sealed proposed construction Plans and the applicable fee.
- 5.2.2 The following data shall be submitted with the request;
- a. Demonstration that proposed work will be performed in Authorization Holder's Authorized Water or Sewer Service Area;
  - b. Legal descriptions of all properties upon which treatment facilities, wells, lift stations, pump stations, or other portions of the Water System or Sewage Disposal System will be located other than mains and lines;
  - c. Description of the facilities to be provided, including a construction schedule showing dates upon which the facilities will be constructed in each portion of the geographical area for which authorization is sought;

- d. Design Specifications of the Plans commensurate with generally accepted design standards and all technical reference manuals and publications listed in Chapters 62-600 and 62-555, Florida Administrative Code;
  - e. Completeness of the engineer's report commensurate with the scale of the project submitted;
  - f. Plans for the project approved by the engineer of the Utility Provider;
  - g. Source and storage capacity (new or existing systems);
  - h. Operator records and reports for the previous 12 months (if applicable);
  - i. Most recent chemical analysis (existing systems only);
  - j. Bacterial Analysis for the previous 12 months (existing systems only);
  - k. Certification of operators;
  - l. Chlorination system;
  - m. Utility corridors in accordance with Chapter VI of this document;
  - n. Capacity of the existing system lines;
  - o. Capacity of the existing treatment plant;
  - p. Parameters of operation with reference to Section 18-31 of the Leon County Code;
  - q. Metering devices;
  - r. Flood plain locations;
  - s. Areas of possible cross-connections;
  - t. Distance between the proposed treatment facility, lift station, pre-treatment facility and nearest residential or commercial structure;
  - u. Systems site plan and layout;
  - v. Well placement and the procurement of all State and federal Permits; and
  - w. Such other data as the County may deem appropriate.
- 5.2.3 Cooperatives with Water Systems and Sewage Disposal Systems regulated by FDEP (i.e. Talquin Electric Inc., and Talquin Water and Wastewater, Inc.) are exempt from providing the requested information in subparagraphs c., e., g., h., i., j., k., and l., in Section 5.2.1.
- 5.2.4 The Department shall actively review a completed Permit request within thirty (30) days and shall notify the applicant of approval or denial of the application. A Permit shall not be issued until all known deficiencies have been resolved.
- 5.2.5 Upon approval, the County shall issue a letter of authorization to the Authorization Holder along with the appropriate Permit. Special conditions may be set out in the letter of authorization.
- 5.2.6 When a hardship can be demonstrated by the applicant, the County may expedite review of the request for a Facility Construction Permit.
- 5.2.7 Prior to the commencement of construction, the Permittee shall obtain and deliver to the County a Performance Bond in an amount to be determined by the County and with a Surety approved by the County or other acceptable security which shall guarantee the completion of all construction and the payment for all labor and materials used in such construction. The County may waive the

requirement for a Performance Bond upon the receipt of other adequate assurance of the Permittee's ability to perform its obligations under the Facility Construction Permit.

- 5.2.8 The applicant, upon receiving the Facilities Construction Permit along with the approved plan, may proceed to construct the facility in accordance with the standards and Specifications outlined in Chapters IV and VII.
- 5.2.9 The Public Water System or Public Sewage Disposal System may be placed in operation after the completion of the construction as outlined in Chapter IV.
- 5.2.10 Approved plans will have an effective life of three (3) years or a life equal to the approved construction, whichever is less, following the approved date stamped on the approved Plans by the Department.
- 5.2.11 Time limit extensions to previously approved Plans may be allowed upon written request to the Department. If the Department determines that the extension does not adversely conflict with changes that have occurred within the Right-of-way within the three (3) previous years, and will not create an adverse impact on the community in relation to previous conditions agreed upon, the extension request will be granted for a period to be determined by the County Engineer.
- 5.2.12 Substantial Changes to the approved facilities construction Plans will be approved only after review and concurrence by the Department.
- 5.2.13 Within ninety (90) days following completion of any construction authorized by the County, the Permittee shall submit the following: a signed and sealed Record Drawings certifying that the system, as installed, is in substantial compliance with the approved application and meets or exceeds the minimum construction standards set forth in Section 18-31 of the Leon County Code and Chapter IV; a certificate of construction completion and clearance for public water system components issued by FDEP, if applicable; and an approval letter or confirmation of acceptance of the system by the Authorized Holder, if applicable.
- 5.2.14 The Performance Bond shall be released upon final inspection and approval by the County.

## **CHAPTER VI**

### **Right-of-way Placement Permit**

#### **6.1.0 Right-of-Way Placement License**

- 6.1.1 Any Person who desires to construct, maintain, repair, operate, or remove lines for transmission of water, sewage, gas, power, other public Utilities, and television under, on, over, across, or within the Rights-of-way shall first obtain a License. A License provides the ability to apply for a Permit, if applicable, and the ability to place or maintain utilities in the Rights-of-way.
- 6.1.2 Although the Florida Public Service Commission has regulatory authority over all Public Water Systems and Public Sewage Disposal Systems serving or proposing to serve over 100 persons, unless exempt from the jurisdiction of the Florida Public Service Commission, the County maintains authority to enforce reasonable rules or regulations regarding the placement, construction or maintenance of all facilities under, on, over, across, or within the Rights-of-way.
- 6.1.3 An Authorized Water or Sewer Service Area shall constitute such License.
- 6.1.4 A License to place Utilities within the Rights-of-Way must be submitted to the Department with the applicable fee.
- 6.1.5 By submitting the application, the applicant agrees to:
- a. Prevent the creation of any obstructions or conditions which are or may become dangerous to the traveling public;
  - b. Require the licensee to repair any damage or injury to the road or highway created during the installation of a Utility facility and to repair said road or highway promptly, restoring the same it to a condition at least equal to that immediately prior to the infliction of such damage or injury; and
  - c. Hold the Board and its members, officers, agents, and employees thereof harmless from the payment of any compensation or damages resulting from the exercise of the privileges granted in any instrument creating such License.
- 6.1.6 The following information and documentation shall be submitted with the application for License to place Utilities within the Rights-of-Way:
- a. Contact information, including an emergency contact;
  - b. The type of Utility;
  - c. A copy of licensee's business registration issued by the State of Florida and any other licenses required by the Florida Public Service Commission, Florida Department of Business and Professional Regulations, or other State or federal agencies;
  - d. Proof of general liability insurance;

- e. A Performance Bond of no less than fifty thousand dollars (\$50,000), or other amount as determined by the County Engineer;
  - f. A brief history and background of licensee; and
  - g. If the Utility Provider is a pass-through Utility (does not serve Leon County residents), state to whom the Utility is to be intended to serve.
- 6.1.7 A licensee shall provide updated information to the County within thirty (30) days of any change in the information required to be submitted for this License.
- 6.1.8 Each licensee shall renew its License by October 1 of years ending in “1” or “6” (such as 2021, 2026, 2031, etc.) in accordance with the licensing requirements of Article IV, Chapter 16, Leon County Code. Failure to renew a License may result in the County restricting the issuance of additional Permits until the Utility Provider has complied with the License requirements of Article IV, Chapter 16, Leon County Code.
- 6.2.0 Registration**
- 6.2.1 Any Communications Services Provider, Wireless Infrastructure Provider, or Pass-through Provider that desires to place or maintain a Communications Facility, conduit, backhaul facility, or Utility Pole intended to support the Collocation of a Small Wireless Facility in the Public Rights-of-way shall first Register with the Department.
- 6.2.2 The following information and documentation shall be submitted with the application for Registration:
- a. The name of the applicant under which it will transact business in the County and, if different, in the State;
  - b. The name, address, electronic mail address, and telephone number of the applicant’s primary contact person and the person to contact in case of an emergency;
  - c. A copy of the applicant's certificate of authorization, public convenience and necessity, or other similar certification or license(s) issued by the Florida Public Service Commission, the Florida Department of State, the Federal Communications Commission, or other federal authority; and
  - d. Proof of the applicant's insurance coverage as required pursuant to Section 16-111, Leon County Code.
- 6.2.3 A Registrant shall provide updated information to the County within thirty (30) days of any change in the information required to be submitted for this Registration.
- 6.2.4 Each Registrant shall renew its Registration by October 1 of years ending in “0” or “5” (such as 2020, 2025, 2030, etc.) in accordance with the registration requirements of Article IV, Chapter 16, Leon County Code. Failure to renew a



Registration may result in the County restricting the issuance of additional Permits until the provider has complied with the registration requirements of Article V, Chapter 16, Leon County Code.

### **6.3.0 General**

6.3.1 Any Person who desires to place or maintain a Communications Facility within the Rights-of-way is required to obtain a Right-of-way Placement Permit in accordance with the procedures outlined in Article V, Chapter 16, Leon County Code. Chapter 6 shall apply to all Persons who desire to place or maintain a Communications Facility within the Rights-of-way, with the exception of Section 6.4.0.

6.3.2 Any Person who desires to construct or maintain any Utility lines within the Rights-of-way is required to obtain a Right-of-way Placement Permit in accordance with the procedures in this Chapter.

6.3.3 Any Person who desires to perform any work within the Rights-of-way, including but not limited to obtaining soil samples or constructing improvements, is required to obtain engineering approval from the Department, unless otherwise exempt by federal, State or local law.

### **6.4.0 Right-of-way Placement Permit**

6.4.1 A Right-of-way Placement Permit is not required for:

- a. Repairs under emergency conditions, such as service failures or public hazards. An after-the-fact Permit application shall be submitted within seven (7) days following the repairs;
- b. Removal, relocation, or adjustments of a Utility in accordance with a project initiated by the County;
- c. Authorized Holders that have obtained a Facility Construction Permit;
- d. Any Person that has obtained a Driveway Connection Permit; or
- e. Any Person that has obtained engineering approval.

6.4.2 Plans submitted with the Right-of-way Placement Permit application shall include:

- a. The type of proposed facility, location of the proposed facility, and the dimensions and the height/depth;
- b. The existing site conditions;

- c. The distance between the proposed facility and nearby pavement, sidewalks, driveways, ramps, trees, underground Utilities and other above-grade and below-grade structures and Utilities;
- d. Sufficient specificity demonstrating compliance with the Florida Building Code, the Florida Department of Transportation's Manual of Minimum Standards, the Utility Accommodation Guide, and the National Electric Safety Code, as amended and as applicable;
- e. Attestation that the proposed facility is to be located within the Rights-of-way, except that if the County Engineer reasonably disagrees the Applicant shall submit a survey;
- f. Trees or landscaping to be removed or impacted.
  - 1. For a proposed tree removal of a protected tree within the Canopy Road Tree Protection Zones, provide additional information and documentation in accordance with Sections 10-4.206(b)(2) and 10-4.206(c)(1) of the Code of Laws.
  - 2. For a proposed tree removal of a protected tree outside of the Canopy Road Tree Protection Zone, provide additional information and documentation in accordance with Section 10-4.206(c)(1) of the Code of Laws.
- g. Description of the installation or construction, such as jack and bore, open cut, or trenching;
- h. Description of the type of material used for the pipes, casing, etc.
- i. Type of soils to be employed and information as to the backfill and compaction operation and type and method of final dressing and road restoration; and
- j. Additional information pursuant to Sections 16-201(c) and 16-302(d), as applicable.

6.4.3 Cross-sections, profiles, key maps, etc. shall be used as needed to provide the above required information.

#### 6.5.0 **Coordination with Other Utilities**

6.5.1 The applicant is responsible for notifying all other Utility Providers or Persons located in the proposed construction area, list the Utility Providers notified on the application, and certify on the permit application that such Utility Providers have been notified in writing. Prior to construction, the Permittee is responsible for contacting Sunshine 811 and notifying the appropriate Utility Providers when construction will begin.

6.5.2 Notified Utility Providers and Persons must submit their objections to the proposed construction to the Department within seven (7) days following the date the application was submitted. To expedite the permitting procedure, the applicant may submit along with the application, signed letters of concurrence from the Utility Providers located in the proposed construction area. The seven (7) day waiting period may be waived by the Department upon receipt of all

appropriate signed letters of concurrence. If objections to the construction are received by the applicant, the objections shall be noted on the Permit application. All correspondence regarding the Permit or construction procedures will be handled directly by the Permittee or their agent.

#### **6.6.0 Proper Corridor for Placements**

6.6.1 Where reasonably possible, Utilities and Communications Facilities shall be placed in the corridors and at depths or heights established in Figures 6.1 and 6.2. Unless otherwise approved by the Department, minimum vertical clearance for underground Utilities will be in accordance with Figures 6.1 and 6.2. Minimum clearance for all aerial Utilities shall be eighteen (18) feet above the Road Surface.

6.6.2 Gas mains shall not be less than 36 inches below the top of the pavement or ditch bottom. When the 36 inch minimum depth cannot be obtained below a ditch bottom without causing technical transmission difficulties, a four (4) inch concrete slab or ditch liner which is two (2) feet wider than the diameter of the transmission line may be utilized; thus not requiring the 36 inch minimum depth. The gas main shall not be less than 18 inches below the concrete slab or liner.

6.6.3 Utility platform structures, such as terminals, transformers, and amplifiers, shall be placed within two (2) feet of the edge of the Right-of-way if possible. Variances from this standard must be approved by the Department.

6.6.4 All Plans accompanying a Permit application shall reflect the use of the appropriate corridors where possible. Approval by the Department shall be on a case-by-case basis when slopes or buffer areas are insufficient to accommodate the Utility in its appropriate corridor, if another Utility is already occupying the corridor, or if another circumstance exists to preclude the Utility from being located in the appropriate corridor.

6.6.5 Communications Facilities shall comply with the locational standards provided in Sections 16-203 and 16-304, Leon County Code.

#### **6.7.0 Existing Drainage Structures**

Drainage culverts, drain pipes, driveway culverts, or other facilities installed for drainage purposes shall not be cut, modified, or removed without obtaining approval from the Department. Drainage structures are sized and installed to accommodate a design flow rate. The placement of facilities should not decrease or otherwise impede the design flow capability of such structures.

#### **6.8.0 Removal and relocation of Facilities from the Right-of-Way**

6.8.1 All abandoned Utility transmission lines and any associated Utility appurtenances shall be removed from the Right-of-way and backfilled to specification, at the Utility's expense, upon the request of the Department.

6.8.2 All abandoned Communications Facilities shall be governed by Section 16-115, Leon County Code.

6.8.3 Removal or relocation of any Utility shall be governed by the provisions of Chapter 337, F.S., as amended, and applicable State or federal laws or regulations.

#### **6.9.0 Duration of the Right-of Way Placement Permit**

6.9.1 A Right-of Way Placement Permit for a Utility or a Communications Facility (other than the collocation of a Small Wireless Facility) shall remain effective for and construction must be completed within ninety (90) days. The Department may extend the expiration of the Permit for good cause. The work permitted by the Right-of-Way Placement Permit shall commence within sixty (60) days of issuance, unless a Permit extension request is submitted in writing fourteen (14) days prior to the expiration date and approved by the Department. Permits will also become void if the installation is not completed within thirty (30) days of commencement, unless this period is extended in writing by the Department.

6.9.2 A Right-of Way Placement Permit for a repurposed structure, as defined in Section 16-102, Leon County Code, or Utility Pole intended to support the collocation of small wireless facilities shall remain effective for and construction must be completed within one (1) year. The Department may extend the expiration of the Permit for good cause. A Permit extension request must be submitted in writing prior to the expiration date.

6.9.3 A Right-of Way Placement Permit for the collocation of a small wireless facility shall remain effective for and construction must be completed within one (1) year. The Department may extend the expiration of the Permit for good cause. A Permit extension request must be submitted in writing prior to the expiration date.

6.9.4 Permits shall not be granted for an indefinite period. If a Permit extension is not timely requested, the Permit shall be void and a new Permit application must be submitted.

#### **6.10.0 Performance Bond**

6.10.1 Prior to the Department issuing the Right-of Way Placement Permit, the applicant shall deliver to the County a Performance Bond as outlined in Chapter I of this document. Typically, the bond will be returned after final inspection and approval.

### **6.11.0 Material Specifications and Construction Standards**

6.11.1 Minimum material standard and Specifications for the construction of Utilities within the Rights-of-way shall be in accordance with minimum standards and Specifications outlined in Chapter VI of this document.

6.11.2 The standards of construction, safety precautions, and road and site restoration shall be in accordance with minimum standards and Specifications outlined in Chapter VII of this document.

### **6.12.0 Unauthorized Placement**

6.12.1 Any Person who places a Utility, or is in the process of placing a Utility, within the Rights-of-way without first acquiring a Right-of-way Placement License and/or Permit is in violation Section 16-81 and this Leon County ROW Manual and is not authorized to commence the placement of the Utility.

6.12.2 Any Person who is in possession of a Right-of-way Placement Permit, but fails to notify the Department in accordance with Section 7.1.3, is in violation of this Leon County ROW Manual, and is not authorized to commence the placement of the Utility.

### **6.13.0 Enforcement**

6.13.1 The County, upon discovering an unauthorized placement of a Utility or the completed placement of a Utility is authorized to act in accordance with the enforcement policies and procedures set forth in Chapter I of this document.

### **6.14.0 Permittee Liability**

6.14.1 The Permittee is responsible for all construction and work performed within the Rights-of-way as determined by the Permit application and attachments during the actual placement and for one (1) year following the date of the final inspection and approval. The Permittee will typically hold a Performance Bond during the construction of the Utility.

6.14.2 Within one (1) year following the date of the final inspection and approval, the Inspector may require repairs due to inferior materials and/or workmanship. The Inspector shall notify the Permittee of the required repairs and arrange a time to inspect the work performed. The Permittee shall not be responsible for damages and/or creations created by other developers, contractors, or local residents.

### **6.15.0 Non-compliance with Placement Permit**

6.15.1 If upon being notified, the Permittee fails to perform Corrective Measures to address a deficiency, the Permittee shall be in non-compliance of the Right-of-

way Placement Permit. The Permittee shall be required to post a Maintenance Bond and retribute any and all cost that the County has incurred to restore the Right-of-way prior to securing another Right-of-way Placement Permit, as outlined in Chapter I of this document.

# RECOMMENDED GUIDE FOR UTILITY PLACEMENT RIGHT-OF-WAY AND EASEMENT WITH CURB AND GUTTER

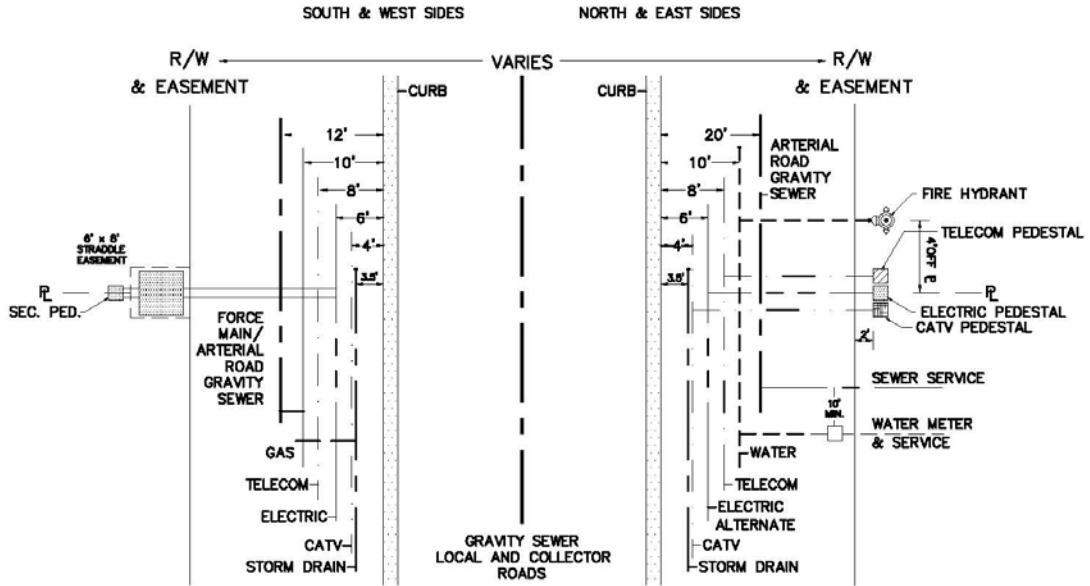

TYPICAL PLAN

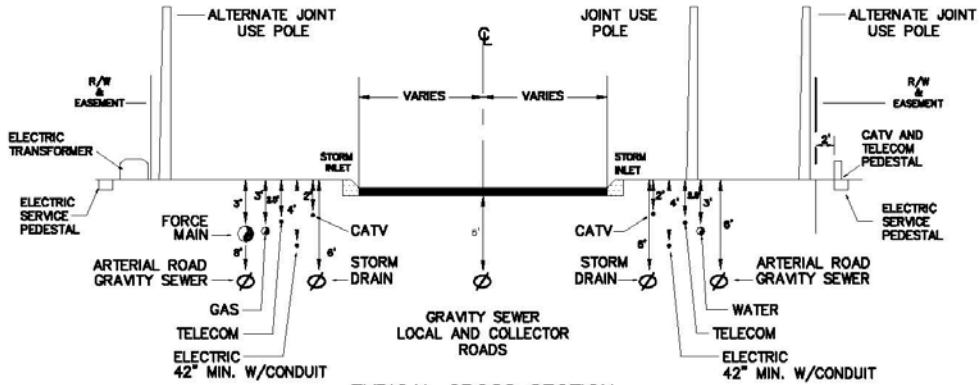

TYPICAL CROSS SECTION

**NOTE:**

THESE PLANS APPLY TO ALL STREET R/W AND EASEMENT WIDTHS EXCEPT WHERE ADEQUATE SPACE BETWEEN EDGE OF PAVEMENT AND R/W IS NOT AVAILABLE OR OTHER FED. OR STATE REGS. APPLY.

ALL DEPTHS ARE MINIMUM BELOW FINISHED GRADES.

FIG. 6.1

DRAWINGS NOT TO SCALE



**LEON COUNTY DEPARTMENT OF PUBLIC WORKS**  
2280 MICCOSUKEE ROAD, TALLAHASSEE, FLORIDA 32308  
PHONE (850) 606-1500 \* FAX (850) 606-1501

Drawn By:	TB
Date:	5/29/2018
Scale:	Custom

**Utility Placement Guide  
Paved Roadway with Curb**

# RECOMMENDED GUIDE FOR UTILITY PLACEMENT RIGHT-OF-WAY AND EASEMENT WITHOUT CURB AND GUTTER

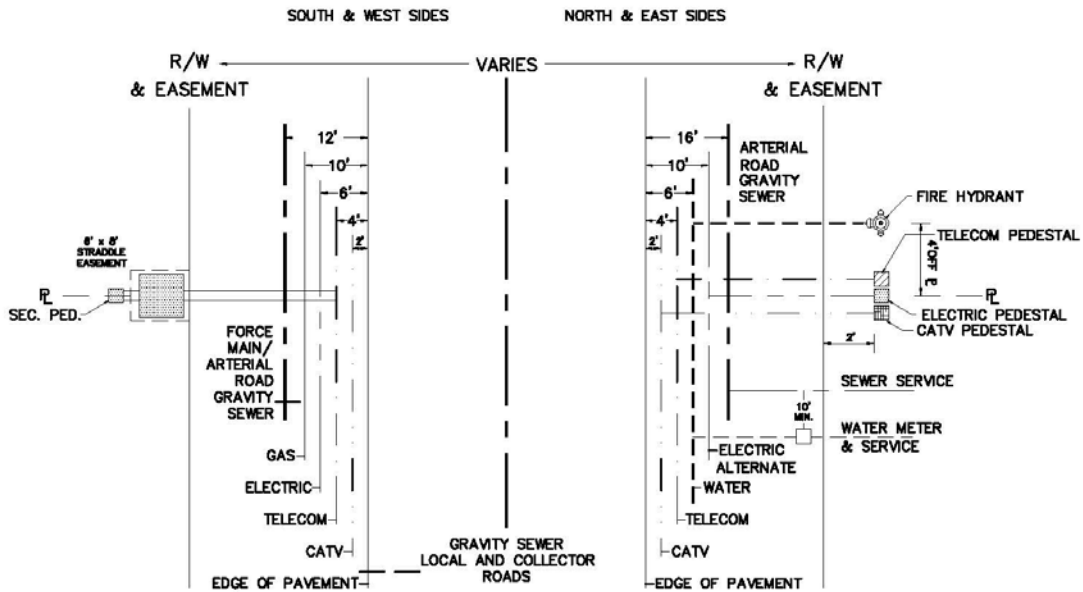

TYPICAL PLAN

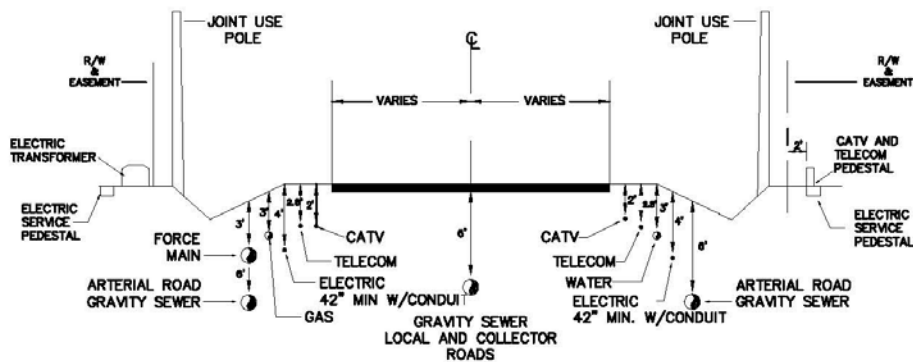

TYPICAL CROSS SECTION

**NOTE:**

THESE PLANS APPLY TO ALL STREET R/W AND EASEMENT WIDTHS EXCEPT WHERE ADEQUATE SPACE BETWEEN EDGE OF PAVEMENT AND R/W IS NOT AVAILABLE OR OTHER FED. OR STATE REGS. APPLY.

ALL DEPTHS ARE MINIMUM BELOW FINISHED GRADES.

FIG. 6.2

DRAWINGS NOT TO SCALE



**LEON COUNTY DEPARTMENT OF PUBLIC WORKS**  
2280 MICCOSUKEE ROAD, TALLAHASSEE, FLORIDA 32308  
PHONE (850) 606-1500 \* FAX (850) 606-1501

Drawn By:	TB
Date:	5/29/2018
Scale:	Custom

**Utility Placement Guide  
Paved Roadway**



## Chapter VII Construction Standards and Specifications

### 7.1.0 Construction Coordination with the Department

The Permittee shall coordinate with the Department prior to performing any construction activities authorized in a Permit. The Permittee shall notify the Department, schedule a pre-construction conference and inspection, and notify the Inspector upon completion of the construction.

#### 7.1.1 Pre-Construction Notification

The Permittee shall adhere to the following schedule when notifying the Department of the Permittee's desired time of construction beginning.

<u>Day</u>	<u>Minimum Prior Notification Time</u>
Tuesday-Saturday	24 hours
Sunday	48 hours
Monday	72 hours

#### 7.1.2 Pre-Construction Conference

A pre-construction conference between the Department and the Permittee's contractor is required prior to construction. Pre-construction conferences will be held at a location specified by the County. These conferences are generally held to discuss plan alternatives, routes, substitutions of materials, and any other topics that might affect the quality, time of construction, and public health, safety, and welfare.

#### 7.1.3 Inspection

- a. Prior to the commencement of the construction, the Inspector shall ensure that the construction personnel are in possession of approved Plans and Permit, discuss any matters concerning the project, and inspect the site. The Inspector may verbally approve the construction to begin and so note on the Plans if requested.
- b. The Permittee and the Inspector may schedule meetings throughout the pre-construction, construction, and post-construction phases of the project. If the Permittee is 1/2 hour or more late to the agreed upon time and place, the Permittee is required to contact the Inspector to schedule another meeting time. If the Inspector is 1/2 hour or more late to the agreed upon time, the Permittee may begin work without an inspection; however, the Permittee is not relieved of the responsibility to comply with the Permit, Leon County Code, this Leon County ROW manual, or other State and local laws and

regulations; and should subsequent inspections reveal deficiencies, the Permittee must correct the deficiencies immediately.

- c. During construction, the Inspector shall monitor the work for compliance with the approved Plans and Specifications. If a deviation or potential deviation is discovered that would require a Substantial Change, all work shall stop except for any Corrective Measures necessary to address the deficiency or to prevent a hazard to the public or any Utility or structure.
- d. The daily log maintained by the Department shall list the notification of construction; and the Permittee shall be bound by the entries made within this log.

#### 7.1.4 Field Changes to Plan

Substantial Changes to the Plans are only permitted after obtaining permission from the Department and the changes have been noted on the previously approved Plans and signed off by the Engineer of Record.

#### 7.1.5 The Project Supervisor

During construction, the Inspector shall monitor the work for compliance with the approved Plans and Specifications. Deficiencies found by the Inspector will be made known to the Project Supervisor. The Project Supervisor shall cause immediate corrections to be made. A Project Supervisor shall be present at all times during the actual construction.

#### 7.1.6 Completion of Construction

The Permittee shall notify the Inspector within one (1) day after the completion of the construction and restoration work and arrange to meet the Inspector at the work site. The Inspector shall inspect the project area and, if no further work is indicated at the time, shall note on the construction Plans that the final inspection has been completed. If either construction or restoration deficiencies are noted, the Inspector shall inform the Permittee and the Permittee shall immediately cause the deficiencies to be corrected and request a re-inspection. A repeat inspection fee may be charged.

#### 7.1.7 Project Completion

If, upon final inspection, the Department has determined that the work site has been restored to a condition equal to or better than that which existed immediately prior to construction, the Inspector shall notify the Permittee that no further restoration action is required at the time and enter the project completion in the official log.

## **7.2.0 Non-compliance with Facilities Construction Permit**

- 7.2.1 Should the Inspector determine that a deficiency in materials or workmanship exists, or Substantial Change from the approved Plans has occurred, the Corrective Measures necessary due to a deviation from the Plans, materials, or workmanship, shall be accomplished by the Permittee immediately upon notification by the Inspector. The Inspector may approve a Grace Period, for Corrective Measures to be completed if the Inspector determines that said deficiency does not place other Utilities, private property, or any structure in jeopardy, nor creates a hazard to the public.
- 7.2.2 A Grace Period shall not be approved when the Inspector determines that further construction of the facility will cause the required Corrective Measures to become more technically or financially impractical to complete at a later date than if the Corrective Measures were completed immediately.
- 7.2.3 The Inspector shall record the specifics of the deficiency or deviation and Grace Period in the Inspector's daily log and on the Department's and Permittee's set of approved Plans.
- 7.2.4 The Permittee assumes any and all liabilities created by the permitted construction and any deficiencies or deviations from the permitted construction.
- 7.2.5 Upon completion of the work to correct the deficiency, and/or at the end of the Grace Period, the Inspector shall review the site to determine if the deficiency has been corrected.
- 7.2.6 If the Inspector determines that the specified Corrective Measures have not been initiated or satisfactorily completed by the end of the Grace Period, the Permittee shall be deemed in non-compliance of the issued Permit. The Inspector shall notify the Department of such non-compliance.

## **7.3.0 Non-compliance with Right-of-Way Placement Permit**

- 7.3.1 The Inspector shall monitor the permitted work for compliance according to the Permit application and attachments and for any conditions set forth by the County. If a deficiency or deviation from the Plans is found during construction or during the final inspection, the Inspector shall notify the Permittee or Project Supervisor of the deficiency, and the Permittee or Project Supervisor shall make Corrective Measures of the deficiency specified by the Inspector. It shall be recorded in the Inspector's daily log that the Permittee is not in compliance with the approved Plans and Specifications. A project shall not be considered complete, and the Inspector shall not sign off on any project, until all deficiencies have been corrected.

- 7.3.2 If the Inspector determines that Corrective Measures are needed immediately to protect the County or private property, or for the protection of the public, the Inspector shall instruct the Permittee to complete the Corrective Measures immediately. If immediate Corrective Measures are not taken by the Permittee, and the state of construction is such that there is a danger or hardship to the public, the Inspector shall arrange for the completion of the Corrective Measures. The County may complete the Corrective Measures and call the Performance Bond. When the County completes the Corrective Measures, the cost incurred by the County to complete the Corrective Measures shall be reimbursed to the County from the Performance Bond proceeds.
- 7.3.3 If the Corrective Measures are not initiated within the time provided to perform the Corrective Measures, the County may complete the Corrective Measures and call the Performance Bond. When the County completes the Corrective Measures, the cost incurred by the County to complete the Corrective Measures shall be reimbursed to the County from the Performance Bond proceeds.
- 7.3.4 If, during the one year following the final inspection and approval, the Inspector finds that further work is required for reasons such as, but not limited to, erosion, backfill subsiding, inferior materials and/or workmanship, the Inspector shall determine the urgency of the Corrective Measure as specified in this Section and notify the Permittee accordingly. The Inspector shall arrange a time to inspect the Corrective Measures.
- 7.3.5 If the Corrective Measures are not completed satisfactorily by the Permittee, the Permittee shall be in non-compliance of the Permit. The County may complete the Corrective Measures and call the Performance Bond. When the County completes the Corrective Measures, the cost incurred by the County to complete the Corrective Measures shall be reimbursed to the County from the Performance Bond proceeds. The Permittee may be required to post a Maintenance Bond prior to the issuance of another Permit by the Department.

#### 7.4.0 **Traffic Control**

##### 7.4.1 Public Safety

- a. Safety devices and the detouring of traffic are utilized to prevent the creation of any obstruction or conditions which may become dangerous to the traveling public, pedestrians, and personnel working at the construction site. The devices are normally visual aids in the form of information, instructional, warning and prohibition signs, barricades, torches, use of flagmen and detour signs.
- b. Maintaining the continuous and safe control of traffic in the permitted work area is the responsibility of the Permittee. Do not maintain traffic over those portions where no work is to be accomplished or where construction

operations will not affect existing roads. Do not obstruct or create a hazard to any traffic during the performance of work, and repair any damage to existing pavement open to traffic. Normal working hours within the County's right-of-ways shall be from 9:00 a.m. to 4:00 p.m., Monday through Friday to avoid conflicts with peak traffic flows. The Permittee may request a deviation from this schedule, which shall be considered by the Department on a case-by-case basis. An exception to the normal working hours will be made for emergency repairs. Failure to follow scheduled work hours may result in revocation of all issued Permits.

#### 7.4.2 Road and Lane Closure Request

Full road or lane closure request shall comply with Policy No. 17-1 – Public Notification of Road Closing.

#### 7.4.3 Initial Signs and Placements

- a. The appropriate above mentioned public safety devices (Section 7.4.1) shall be in place prior to the placement of material or equipment on a work site that would require such safety precautions.
- b. As work begins and progresses, signs and flagmen shall be placed, replaced, moved or taken down, accordingly, to provide maximum information and safe road conditions for the traveling public. The instruction set forth in the *Manual on Uniform Traffic Control Devices for Streets and Highways* by the U.S. Department of Transportation will be strictly adhered to as minimum requirements. The Permittee may voluntarily increase sign requirements as a situation warrants or the Inspector may direct additional signs or relocation of existing signs.
- c. The placement of signs for convenience to the Permittee and which are detrimental to the traveling public is prohibited.

#### 7.4.4 Detour Routes

- a. Detour routes may not be established where the public would be unreasonably inconvenienced as determined by the Department. Plans to detour traffic must be included in construction and Right-of-way Permit applications.
- b. The responsibility to place the necessary signs, flagmen, and other safety devices on approved detour routes is the same as for the work area.

#### 7.4.5 County Public Road Signs and Property

The Permittee shall be responsible for removal and replacement of any existing County road signs or property that interferes with the authorized construction operation. Any damaged property shall be replaced by the Permittee at the Permittee's expense. Damage to the paved surface shall be repaired to the satisfaction of the County, which may include milling and overlaying the full width of the Road Surface as determined by the Department.

#### 7.4.6 Aerial Utility Installation over Roadways

- a. When lines are being placed over traffic lanes, warning signs shall be placed at appropriate distances on each end of the work area. Flagmen will be posted to warn on-coming motorists during the entire crossing operation. After all conductors have been pulled in and secured, the bucket truck, flagmen, and warning signs will be removed from the roadway. Conductors will not be energized for any reason during construction.
- b. At no time will the road be open to traffic when over-head lines are less than eighteen (18) vertical feet from the Road Surface.
- c. Procedures for crossings of high voltage lines across major County roads when guard poles are needed will be approved by the Department on an individual basis.

#### 7.4.7 Use of Signs

- a. Street and highway construction and maintenance signs fall into three major categories: regulatory signs; warning signs; and guide signs. Many signs normally used elsewhere will find application for signing construction and maintenance operations.
- b. Construction and maintenance signs shall follow basic standards for all highway signs as to shape. Warning signs in construction area shall have a black legend on an orange background. Existing yellow warning signs already in place within these areas may remain in use. Color for other signs shall follow the standard for all highway signs. The use of striped (other than the standard border) or other geometric patterns or contrasting colors on or around any sign in an attempt to make it more conspicuous, distracts attention from the message and defeats the purpose of maintaining uniformity and simplicity of design. Such practice is contrary to standards and is accordingly disapproved. However, warning lights in conjunction with signs is permitted, so long as they do not interfere with a clear view of the sign face.
- c. After daylight hours, signs are to remain erected, but illuminated or reflectorized.

- d. Design and color of regulatory and warning signs shall be in conformance with the *Manual of Uniform Traffic Control Devices for Streets and Highways* published by the U.S. Department of Transportation.

#### 7.4.8 Drums, Barricades, and Other Commonly Used Signs

- a. The design, color, and application of drums, barricades, and all other regulatory and information signs shall be in conformance with the *Manual of Uniform Traffic Control Devices for Streets and Highways* published by the U.S. Department of Transportation.
- b. The "ROAD CLOSED" sign shall be used where the roadway is closed to all traffic except contractor's equipment or officially authorized vehicles. The sign is to be erected at or near the center of the roadway on or above the appropriate barricade. The "ROAD CLOSED" sign shall not be used where traffic is maintained or where the actual closure is some distance beyond the sign.
- c. The "LOCAL TRAFFIC ONLY" sign should be used where through traffic must detour to avoid closing of the road or street some distance beyond and by where the road or street is open for traffic up to the point of closure. It shall carry the legend "ROAD CLOSED (10) MILES AHEAD--LOCAL TRAFFIC ONLY" or optionally for urban use, "STREET CLOSED TO THROUGH TRAFFIC," and shall be accompanied by the appropriate detour signing.

#### 7.5.0 Excavation-Pipe Installation-Backfilling

##### 7.5.1 Clearing and Grubbing

- a. Vegetation such as trees, shrubs, and grass, which interferes with construction, may be removed, except for certain trees and shrubs which are designated to remain undisturbed. Vegetation removal shall be minimized to the extent practicable. All shrubbery, ornamental trees, and other such plantings including those within construction areas shall be satisfactorily replaced before the final approval of construction. All areas disturbed during construction shall be restored to a condition equal to or better than that existing prior to beginning work. All clearing and grubbing shall be performed in accordance with Leon County's Environmental Management Act (Chapter 10, Article IV, Leon County Code).
- b. Trimming of branches or roots shall be limited to minimum clearance necessary, and accomplished by making clean, unbroken cuts. Wounds on limbs or roots ½ inch in diameter or greater shall be painted with a suitable protective compound. Tree impacts and any necessary mitigation shall be conducted consistent with applicable requirements outlined within the Tree

Protection Subdivision of the Environmental Management Act (Reference Sections 10-4.361 through 10-4.364, Leon County Code).

### 7.5.2 Control of Water

- a. Control of ground water shall be such that softening of the trench floor or of visible water shall be prevented. Dewatering systems shall be designed and operated so as to prevent removal of natural soils. All water discharged from the site shall meet all State and federal regulations and proper permits shall be obtained by contractor and displayed onsite prior to discharge activates.
- b. Static water level shall be drawn down below bottom of excavation so as to maintain undisturbed state of natural soils and allow placement of backfill to required density. A dewatering system shall be installed and operated so that the ground water level adjacent to the excavation is not reduced to the extent which would damage or endanger nearby structures or property.
- c. Release of ground water to its static level shall be performed in a manner so as to maintain an undisturbed state of natural foundation soils, prevent disturbance of compacted fill or backfill, and prevent floatation or movement of all structures and pipelines.
- d. Deviation from these procedures shall only be allowed when a suitable alternative, approved by the Inspector, is used which will adequately address the problem.
- e. Dewater and dispose of water so as not to cause injury to the public or private property or to cause a nuisance or a menace to the public. The Contractor shall at all times have on hand sufficient pumping equipment and machinery in good working condition for all ordinary emergencies and shall have available at all times competent workmen for operation of pumping equipment. Dewatering systems shall not be shut down between shifts, on holidays or weekends, or during stoppages without written approval from the Department.

### 7.5.3 Excavation

- a. All construction activities shall strictly adhere to the Occupational Safety and Health Administration ("OSHA"), Department of Labor regulations, 29 CFR Part 1926, for trenching and excavation.
- b. All excavated material retained for backfill shall be piled in a manner so as not to endanger the work or obstruct sidewalks, driveways, or drainage. Fire hydrants, valves boxes, Utility boxes and other Utility controls shall be unobstructed and accessible at all times during construction.



- c. Trenches shall be excavated to the required depth and to a width sufficient to provide the necessary working room only. If the trench is on or along a Roadbed, saw cut the pavement in a neat, straight line. Trench sides shall be vertical up to at least the mid-point of the horizontal pipe. Loose pavement materials must be removed from the immediate area, taking precautions not to mix with soils intended for backfill. If excavation is carried below what is required, the overcut depth shall be backfilled with suitable bedding material and compacted to 95% of maximum density. Voids of ample size shall be cut under and around all joints to assure that the barrel of the pipe rests uniformly and in continuous with the supporting ground for its entire length.
- d. The compaction of fill material for Utility trenches under improved areas shall be 100% of density, as measured by Standard Proctor.
- e. When rock is encountered, the excavation shall continue to a depth of at least six (6) inches below the required grade and backfilled to grade with six (6) inches of suitable fill.
- f. Where pipe laying ceases at the end of the day or for any cause, the end of the pipe shall be securely closed in order to prevent the entrance of water, mud, or any other objectionable matter.

#### 7.5.4 Sheeting and Bracing

- a. It is the responsibility of the Permittee and/or Engineer of Record to provide for support of the trench walls when needed.
- b. Where sheet pilings, shoring, sheeting, bracing or other supports are necessary to protect adjacent property or the work and necessary for safety of the workmen or the public, they shall be designed, furnished, maintained and removed by the Permittee or their designee.
- c. Design, planning, installation and removal of all sheeting, shoring, sheet piling and bracing shall be accomplished in a manner so as to maintain required trench or excavated section with an undisturbed state of soils at and below excavation bottom and must adhere to OSHA and Florida Trench Safety Act requirements.
- d. Movable trench boxes may be used and must comply with OSHA and Florida Trench Safety Act requirements.

#### 7.5.5 Pipe Laying and Jointing

- a. With the exception of the requirements specified in Chapter 6 for all water and sewer piping, the following standards for pipe laying shall be adhered to where applicable:

<u>Material</u>	<u>Standard</u>
Cast or Ductile Iron Pipe	ANSI/AWWA C600 (except testing and sterilization), AWWA Manual M41
PVC Pipe	ASTM D2321
HDPE Pipe	ASTM D2321

- b. Pipe shall be laid either on a prepared bed or undisturbed earth in bottom of trench shaped as required to fit pipe or upon a layer of properly placed bedding material.

#### 7.5.6 Unsuitable Material below Pipe Grade

- a. Unsuitable materials are soils exposed at the trench bottom of obtained from the Permittee's excavations that are compressible, expansive, contain extraneous rubble, offer uneven foundation support or have natural moisture content three percent or greater in excess of its optimum moisture content. Unsuitable materials/soils include, but are not limited to mulch, expansive clays, boulders, muck, rubble, any portion of trees or similar vegetation, wood or unyielding material such as rock.
- b. Whenever excavation exposes unsuitable materials, which in the opinion of the Inspector is unsuitable foundation to support the pipe, the material shall be removed to a depth necessary to reach material having adequate bearing capacity. The unsuitable material shall be replaced with 6 inch minimum of select backfill (Type "B", Section 7.3.9) up to the bottom of the pipe envelope.

#### 7.5.7 Placing Backfill

- a. After the pipe has been properly laid and inspected, suitable backfill (Type "B", Section 7.5.9) shall be carefully placed and compacted around the pipe up to the spring line of the pipe. Backfill materials shall be carefully placed in loose horizontal layers not exceeding six (6) inches in loose depth and equally on both sides of the pipe and shall be spaded, "walked in" and compacted to obtain a minimum density of 90% of maximum density as determined by ASTM D698 (Standard Proctor Density), except for depths ten (10) feet or less, where the minimum density allowed shall be 95% minimum density. When one layer is completed on both sides of the pipe, a second layer shall be started. Backfill materials shall not be obtained from trench walls.
- b. The Permittee may elect to place material in thicker lifts of no more than twelve (12) inches compacted thickness above the soil envelope if the Permittee can demonstrate with a successful test section that density can be achieved. The Permittee must notify the Inspector prior to beginning construction of the test section.

### 7.5.8 Subsequent Backfill

- a. Above the level of the initial backfill, the trench shall be filled with material placed in accordance with one of the following Specifications: Florida Department of Transportation, Leon County, or Specifications by other overseeing authorities. In improved areas, or areas proposed to be improved, the Utility trench shall be backfilled with select backfill (Type "B", Section 7.5.9) only; and the surface of the trench shall be prepared to receive base construction.
- b. The compaction of fill material for Utility trenches under improved areas shall be 100% of density, as measured by Standard Proctor.
- c. In unimproved areas, and areas not proposed to be improved, the excavated top soils shall be used last in the backfill, and the surface of the trench restored to its original elevation and condition.
- d. The compaction of fill material for Utility trenches under unimproved areas shall be 95% of density, as measured by Standard Proctor, within the pipe envelope. The compaction of fill material for the remainder of the trench shall be compacted to firmness approximately equal to that of the soil adjacent to the pipe trench.

### 7.5.9 Type "B" Material

- a. Type "B" material, per OSHA, 29 CFR 1926 Subpart P Appendix A, shall be a select granular material free from organic matter and of such a size and gradation that desired compaction can be readily attained. When tested in accordance with the latest ASTM D6913, it shall conform to the following requirements:
  1. Maximum size not to exceed three (3) inches.
  2. At least 95% shall pass through a one and one-half (1-1/2) inch sieve and not more than 10% shall pass through a No. 200 sieve.
  3. Uniformity Coefficient shall be six (6) or greater.
  4. Material shall have a sand equivalent of 35% or greater.
- b. Material may be clean, natural sand or gravel, imported quarry waste, select excavation or mixture thereof.

#### 7.5.10 Type "D" Material

Type "D" material shall be obtained from the contractor's excavations. Such backfill material shall be free of debris, deleterious materials, organic materials, and expansive soils, and shall contain no material larger than four (4) inches.

#### 7.5.11 Gravel Base

Gravel base shall be clean, washed, well-graded rounded gravel or crushed rock of one and one-half (1-1/2) inch maximum size and three-eighths (3/8) inch minimum size.

#### 7.5.12 Bedding Material

- a. Bedding material shall be three-fourths ( $\frac{3}{4}$ ) inch nominal size coarse aggregate. When tested in accordance with latest ASTM D6913, it shall conform to the following gradation requirements:

Passing 1 inch sieve	100%
Passing $\frac{3}{4}$ inch sieve	90-100%
Passing $\frac{3}{8}$ inch sieve	20-55%
Passing No. 4 sieve	0-10%

- b. Bedding material for PVC force main shall be free from any rock, stone, or gravel larger than three-fourths ( $\frac{3}{4}$ ) inch for a distance of twelve (12) inches from the pipe.
- c. Material shall be free from soft, laminated, or thin pieces.

#### 7.5.13 Backfill for Structures

Backfill for structures shall be compacted select sand backfill as specified above for a minimum distance of ten (10) feet from the outside wall of the structure or to undisturbed excavation wall if nearer.

#### 7.5.14 Use of Shrinkless Grout

In lieu of the use of backfill materials stated above, the County Engineer may require shrinkless grout if adequate coverage of pipe cannot be achieved.

In order to allow grasses and other natural cover to establish itself, the final six (6) inches of trench located off of the travelled surface of the right-of-way shall be filled with the excavated topsoils and shall be compacted.

#### 7.5.15 Compaction by Flooding

The Permittee may compact granular backfill materials above level of initial backfill materials above level of initial backfill by flooding provided he has secured prior approval from the Inspector for each location. When compaction by flooding is to be done, backfill materials shall be coarse grained gravel, gravel-sand or sand, free of clay, having not more than five percent by weight which passes a No. 100 U. S. standard sieve and no material which passes a No. 200 U. S. standard sieve. In addition, the character of soil through which trench passes shall be clay-gravel or gravel-sand-silt mixtures which possess permeability sufficient to result in flooding water being drained away in a reasonable time not to exceed three days. All tests required to determine if backfill material or soil adjacent to the trench is suitable for compaction by flooding shall be the sole responsibility of the Permittee.

#### 7.5.16 Disposal of Surplus Materials

The unauthorized disposal of surplus material on private property or within the Rights-of-way or easements is strictly prohibited. The Permittee shall indicate to the Inspector the area to be used for the disposal of surplus material and provide evidence of authorization to the Inspector showing that the Permittee has the right to use this area. If no area is available for this purpose, the County Landfill is to be used.

#### 7.5.17 Dust Control

Pursuant to Leon County Land Development Code, construction sites with land disturbance activity shall adhere to a dust control plan sufficient to prevent: off-site nuisance conditions; hazardous on-site conditions; and adverse impacts to stormwater runoff. Dust control plans shall follow standard best management practices. If the Inspector determines that dust has become a nuisance during the construction period, the Permittee shall employ additional measures as necessary to mitigate the condition.

### 7.6.0 **Jack and Bore**

The work shall include the installation of casing pipe by the method of boring and jacking as specified within this Section. The work shall include, but not limited to, boring and jacking pits, equipment, sheeting, steel casing pipe, casing spacers, coatings, location signs as required, and miscellaneous appurtenances to complete the entire work.

#### 7.6.1 Material Requirements

- a. **Steel Casing Pipe.** Steel casing shall conform to the requirements of ASTM A139 Grade B with minimum yield strength of 35,000 psi. Field and shop welds shall conform to American Welding Society (AWS) standard specifications. Field welds shall be complete penetration, single-bevel groove type joints. Welds shall be leak-proof, airtight, and continuous over the entire

circumference of the pipe and shall not increase the outside pipe diameter by more than three-fourths (3/4) inch.

- b. Carrier Pipe. All pressurized carrier pipes for jack and bore installations shall be restrained joint ductile iron pipe, and shall be lined and coated in accordance with Chapter IV Section 4.2.2 (b.) for water services or Section 4.3.2 (b.) for sewer services. Gravity sewers with bore lengths less than sixty (60) feet can be DR 26 PVC sewer pipe. Gravity sewers sixty (60) feet or greater in length must be restrained joint ductile iron pipe, lined for sanitary sewer application.
- c. Casing Spacers. Carrier pipes, inside of steel casing pipe shall be supported by casing spacers at no more than six and one-half (6.5) feet between spacers with double spacers on each end of the casing at a maximum of two (2) feet behind the bell. Each spacer shall be a minimum of eight (8) inches wide for twelve (12) inch diameter or less carrier pipes and a minimum of twelve (12) inches wide for sixteen (16) inch diameter or greater carrier pipes.

The spacer shall be manufactured of a minimum of 14-gauge Type 304 stainless steel. A minimum of three casing spacers per carrier pipe segment is required. Spacers on the spigot end shall be positioned at the line marking the insertion limit into the bell, such that the casing spacer is in contact with the bell face when the pipe is properly seated. Each spacer shall have a minimum of four runner supports manufactured of an ultra-high molecular weight polyethylene or glass reinforced polymer. The runner supports shall be of adequate height to position the carrier pipe in the center of the casing with a minimum top clearance of one and one-half (1.5) inches. All nuts, bolts and washers shall be Type 304 stainless and compatible with the respective Type 304 stainless steel shell and band.

- d. Casing End Seals.
  - 1. Mechanical link-type casing end seal: Shall be interlinked rubber sealing elements that are compressible to create a water-tight seal between the casing pipe and the carrier pipe. The seal shall be manufactured from EPDM rubber elements with composite compression plates and stainless-steel nuts and bolts.
  - 2. Skirt-type casing end seal: Shall be seamless rubber with stainless steel straps for securing the seal to the carrier pipe and the casing pipe. End seals shall be constructed of one-eighth (1/8) inch thick, specially compounded synthetic rubber with stainless steel banding straps.

## 7.6.2 Installation Requirements

- a. Pit Excavation. The construction shall not interrupt traffic on the roadway. The pit shall be no closer than four (4) feet from the edge of pavement or two (2) feet from a curb section, unless otherwise authorized by the Department. The pit shall also be excavated and backfilled in the manner described in Section 7.5.0 of this Chapter.
- b. Casing Pipe Installation. The installation of the casing pipe shall proceed from a pit excavated no closer than four (4) feet from the edge of the roadway, railroad, or other structure. Construction shall not interrupt traffic on the roadways or railroads. All horizontal and vertical locations of underground utilities shall be verified in the field. Maintain dry jacking and receiving pits and boreholes, free from groundwater infiltration or stormwater runoff. Dewatering through the casing pipe is not permitted.

Casing pipe shall be installed in accordance with approved jacking and boring methods. Install suitable reaction blocks for the jacking operation, as required. Jacking operations shall be continuous and precautions shall be taken to avoid interruptions that might restrict or prohibit the advancement of the casing pipe. Earth within the casing shall not be removed too close to the cutting edge in order to prevent the formation of void outside the casing. If voids are formed, they shall be satisfactorily filled with grout by pumping. Installation of the casing pipes shall be at a horizontal and vertical alignment that will allow installation of the carrier pipe.

The joining of sections of steel casing shall be field welded in accordance with applicable portions of AWWA C206 and AWS D7.0 for field welded pipe joints. The contractor shall wire brush the welded joints and paint with an approved material.

- c. Carrier Pipe Installation. All carrier pipes shall be installed with approved casing spacers meeting the requirements of Section 7.6.1 (c) of this Chapter. All casing spacers shall be installed in accordance with the manufacturer's recommendations.

## 7.7.0 Directional Bore

The contractor shall furnish and install underground pressure mains using the horizontal directional drilling (HDD) method of installation, or directional boring. The work shall include all drilling equipment, materials, piping, appurtenances, and labor for the complete and proper installation, testing, and placing into service of pressurized mains.

### 7.7.1 Material Requirements

- a. Drilling fluid shall be a gel-forming colloidal fluid consisting of at least 10% high-grade bentonite, which is totally inert and contains no environmental risk, or equal.
- b. Pressure Main Pipe shall be fusible HDPE or PVC pipe with ductile iron pipe size (DIPS) outside diameters (OD) in accordance with AWWA C906 or C900, respectively. The DR of the pipe shall be based on the pipe material, joint type, drilling rig specifications, and in-situ conditions, and shall be suitable to withstand the pull-back forces required for the directional drilling without permanent deformation in the pipe section or strength.
- c. 4 inch or greater HDPE pipe (AWWA C906), the maximum DR shall be DR11. For 4 inch through 12 inch PVC pipe (AWWA C900), the maximum DR shall be DR18.
- d. Fusible HDPE and PVC pipe for horizontal directional drilling applications shall be joined by means of zero leak-rate thermal butt-fusion welds. Joints shall provide axial pullout resistance. The bending radius shall not exceed 80% of the manufacturer's recommended maximum bending radius for the size and type of pipe.

#### 7.7.2 Installation Requirements

- a. Erosion and sedimentation control measures and on-site containers shall be installed to prevent drilling mud from spilling out of entry and/or exit pits. Drilling mud shall be disposed of off-site in accordance with local, State, and federal requirements and/or Permit conditions. No other chemicals or polymer surfactant shall be used in the drilling fluid without written consent of the County and after a determination is made that the chemicals to be added are not harmful or corrosive to the facility and are environmentally safe.
- b. Pilot Hole: Pilot hole shall be drilled on bore path with no deviations greater than 2% of depth over a length of 100-feet. In the event that pilot does deviate from bore path more than 2% of depth in 100-feet, the Contractor shall notify the County. The County may require the Contractor to pullback and re-drill from the location along bore path before the deviation.
- c. Reaming: Upon successful completion of pilot hole, the Contractor will ream borehole to a minimum of 25% greater than outside diameter of pipe using the appropriate tools. Contractor will not attempt to ream at one time more than the drilling equipment and mud system are designed to safely handle.
- d. Pullback: After successfully reaming borehole to the required diameter, Contractor shall put the pipe through the borehole. In front of the pipe shall be a swivel and barrel reamer to compact bore-hole walls. Once pullback operations have commenced, operations must continue without interruption



until pipe is completely pulled into borehole. During pullback operations, the Contractor shall not apply more than the maximum safe pipe pull pressure at any time. A break away head rated at the maximum safe pull pressure shall be utilized.

- e. The pipe entry area shall be graded to provide support for the pipe to allow free movement into the borehole. The pipe shall be guided in the borehole to avoid deformation of, or damage to, the pipe.
- f. If unexpected subsurface conditions are encountered during the bore, the procedure shall be stopped. The installation shall not continue until the County has been consulted.
- g. The pipe shall be pulled back through the borehole using the wet insertion construction technique. The pipe shall be installed full of water.
- h. The pipe shall be installed in a manner that does not cause upheaval, settlement, cracking, movement or distortion of surface features.
- i. A boring log shall be kept with horizontal and vertical location every 10 feet. The horizontal location of the bore shall be marked in the field during the bore. The Surveyor shall locate these marks and include this information with the bore depths in the Record Drawings. The Surveyor may make a note on the drawing page containing the directional drill and provide an exception for the directional drill only, as the directional drill route cannot be uncovered and physically located.
- j. The pipe shall be installed at a depth of no more than fifteen (15) feet below pavement, as measured from the top of pipe.

#### **7.8.0 Casings**

7.8.1 Casings are required for underground crossings of utilities where the carrier conduit is on insufficient strength due to composition or cover or such that it cannot reasonably be jacked.

7.8.2 When casing is used for transporting flammable gasses or fluids, the casing should extend to the top of the slope and be vented at the outside of the right-of-way line.

#### **7.9.0 Codes and Standards**

The latest edition of the established standards of the following organizations shall be followed as if they were fully written herein and constitute a part of the specification requirements, except where otherwise specified:

- a. National Fire Protection Association - "National Electrical Code".
- b. Occupational Safety and Health Administration - "O.S.H.A."
- c. Appropriate Leon County Ordinances, Policies, Rules, and Regulations.

**7.10.0 Road Restoration**

**7.10.1 General**

- a. Restoration of pavement cuts will be handled in the following manner (Refer to Figures 7.1 for details).
- b. Full road width paving is required when a cut is made in a paved road for more than 50 linear feet. The area beginning 50 feet before the cut and 0 feet beyond the cut must be paved the full width of the existing pavement with a minimum of one inch of Type SP-9.5 asphalt in addition to normal patching.
- c. Full road width paving shall also be required when multiple lateral cuts are made on a section of road and it is determined by the Department that the number of cuts and closeness of cuts accumulated and/or proposed severely reduce the structural integrity of the Road Surface or subgrade. Roads that have been resurfaced in the past 5 years shall be milled and overlaid 50 feet each side of the open cut/patch.
- d. Restoration of the road base is accomplished by placing 6 inches of 100 LBR limerock base, and compacted to 98% modified proctor. It is then capped with 2 inches of super paved asphalt. Edges of the cut must be tacked prior to asphalt placement.

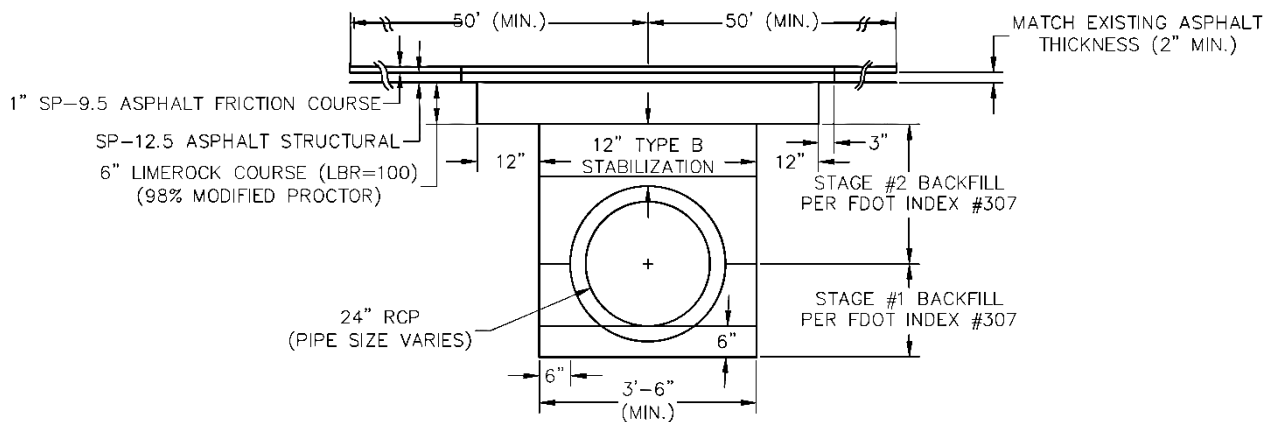

**FIGURE 7.1 TRENCH CUT TYPICAL DETAILS**

N.T.S.

**7.11.0 Surface Preparation**

Prepare the surface by cutting back the pavement 12 inches on both sides of the trench to a total depth of 6 inches, exposing the road base. Immediately remove all loose materials, storing them away from the work area. The cut is made with tools approved by the Inspector.

#### **7.12.0 Asphalt Patch**

7.12.1 It is important that the bonding surface is clean and free of all loose material so that the tack material seals properly. Before the asphalt can be placed, the bonding area must be uniformly tacked with RS-2 emulsified asphalt or other comparable materials approved by the Inspector. Rate of tack application is 0.10 gallons per square yard. The coat may be applied by hand methods using cloth materials such as mops or rags for linear cuts or longitudinal cuts of less than 50 linear feet. Pressure distribution must be used when cuts are more than 50 feet in length to prevent the tack materials from solidifying and losing adhesive characteristics prior to applying the asphalt. Normally, the patch material will be placed and compaction begun within 15 minutes after tacking.

7.12.2 All asphalt materials must arrive at the work site at 230° to 310° and not less than 205° prior to the compaction operation.

7.12.3 The patch job is complete when the appropriate patch material is placed back in one-inch compacted lifts, if using a small upright compactor, or two-inch compacted lifts, if using a layer type compactor, until the seams of the patched surface area are level with the existing pavement and the patch is crowned ¼ inch to prevent the patch from sinking below the existing pavement due to settling.

#### **7.13.0 Manhole Openings and Other Appurtenances**

When a manhole, valve box, or other appurtenance is placed in a County right-of-way, it shall not be recessed or project more than ¼-inch above the finished pavement or restoration grade.

To restore a road cut around a manhole, cut the pavement back to subgrade 12 inches from the manhole or appurtenance leaving clean, even margins. Backfill the excavated area around the manhole riser and frame with compacted fill, sub-base, and road base material to match the typical road section. **DO NOT USE CONCRETE COLLAR.** Install matching asphalt mix patch to bring the final surface flush with the finished Road Surface.

7.13.1 Top slabs of manholes will not be located closer than one (1) foot beneath the surface of the road unless an acceptable alternative to secure the manhole structure is provided. Prior approval by the Department is required for an exception to the one (1) foot rule. Overlays performed in the area of the

manholes, valve boxes, etc. will require the advanced raising of these items in conjunction with the Utility Provider and the Department. Suitable riser ring inserts may be allowed upon approval by the Department.

#### **7.14.0 Unpaved Roads**

When unpaved roads or any portion of a right-of-way is cut, the cut area must be compacted back to obtain equal or greater density of the adjacent undisturbed soils.

The Permittee shall be responsible for and maintain the immediate complete restoration work for a period of one year from the date of final inspection. The Permittee shall not be responsible for damages or conditions created by a third party, except if caused by inferior work by the Permittee.

The area cut must be leveled and any soil evenly distributed. Seeding, sodding, and shrubbery procedures are found in Sections 7.16.0 through 7.20.0 of this Chapter.

7.14.1 The tops of manholes will not be located closer than one-foot beneath the surface of the road unless an acceptable alternative method which will secure the manhole structure is provided. Prior approval by the Department is required for an exception to the one-foot rule.

#### **7.15.0 Final Dressing**

7.15.1 Cleanup is an essential part of the work. As work progresses and is completed, the Permittee shall clean the site of all signs of operation. The cleanup shall be done as promptly as practical and shall not be left until the end of the construction period. The final inspection will not be complete until all areas are restored to original or better condition.

7.15.2 Included in cleanup is protection of road Shoulders, ditch banks, and other natural or artificial slopes subject to rapid erosion. Except where there is soil-cement riprap, this protection shall be by grassing and mulching. A sufficient stand of grass shall be obtained by sprigging, sodding or seeding over the entire work site.

#### **7.16.0 Grassing and Mulching**

When applicable, grassing and mulching of all disturbed areas shall begin immediately after construction is completed and before inspection. Any yards or parts of the Rights-of-way in front of private property which have a grass mat will be re-sodded with like sod, or to the satisfaction of the Inspector.

#### **7.17.0 Sodding**

Immediately before sod is placed, an appropriate fertilizer shall be applied at the rate specified by the manufacturer to promote fast healthy growth. Fertilizer shall be applied consistent with the County's fertilizer requirements as outlined within Article 14 of the Land Development Code including presence of at least one person holding a current county-approved best management practices training certificate during fertilizer application. The sodded area shall be watered appropriately. Water shall be provided by the Permittee at his expense and whenever necessary to assure sustained growth and vitality.

#### **7.18.0 Seeding**

All areas to be seeded shall be fertilized at the rate specified by the manufacturer to promote fast healthy growth and thoroughly worked into the soil. All seed and fertilizer used shall meet the requirements of the State Department of Agriculture and all applicable State laws. Fertilizer shall be applied consistent with the County's fertilizer requirements as outlined within Article 14 of the Land Development Code including presence of at least one person holding a current county-approved best management practices training certificate during fertilizer application.

Erosion prevention, repairs, replanting, reseeding, and re-sodding of the construction area shall be the responsibility of the Permittee until the soils and surface are stabilized.

#### **7.19.0 Mulching**

Seeded area shall be uniformly mulched in a continuous blanket immediately following seeding at a rate of 1 ½ tons of hay or straw per acre. Hay with noxious seeds or plants is not acceptable. Decayed, moldy, or brittle hay is not acceptable. The thickness shall be adequate to hold the soil, but loose enough to favor the development of grass. Immediately following the mulch distribution, the mulch shall be anchored to the soil by means of a seed drill, disk harrow set to cut only slightly, or other suitable equipment which will secure the mulch and prevent loss or bunching by wind or rain. String lines placed at sufficient intervals is also acceptable.

On slopes where machinery cannot be used, mulch may be anchored in place by hand or spading, string lines, or non-metallic open weave fabric. Mulched areas shall be watered immediately after distribution and anchoring.

#### **7.20.0 Hydro-Seeding**

7.20.1 Under this method, the seed, fertilizer, and mulch are mixed with water which produces a slurry. The slurry shall be distributed over the area to be seeded. The type of seed and fertilizer and the requirements for seed, fertilizer, and water as specified shall apply to this work. Fertilizer shall be applied consistent with the County's fertilizer requirements as outlined within Article 14 of the Land Development Code including presence of at least one person holding a current

county-approved best management practices training certificate during fertilizer application.

The equipment for mixing the slurry and for applying the slurry over the areas to be seeded shall be capable of applying uniform slurry over the entire area and shall meet the approval of the Inspector.

7.20.2 The mulch material shall be included in the slurry mixture and shall be applied at a rate of 1,000 pounds of mulch mixture per acre. Mulch material shall consist of wood cellulose fiber material especially prepared for this purpose. It shall be prepared in such a manner that it will contain no growth-inhibitors or germination-inhibiting factors and shall be dyed an appropriate color for readily determining the rate of spread by visual observation. The slurry shall be uniform and homogenous, forming a blotter like ground cover and impregnated uniformly with grass seed. Rainfall and water shall be able to percolate to the under-soil. Other types of mulch material may be used after review by the Engineer or Inspector.

7.20.3 The Permittee shall, at his expense, maintain the grassed areas in a satisfactory condition until the grass has reasonably sprouted and taken hold.

#### **7.21.0 Record Drawings**

7.21.1 Utility work performed in Rights-of-way shall not be accepted until certified Record Drawings are delivered to the Department and approved by the County Engineer. The delivered Plans will be certified by the Engineer of Record for accuracy of the installation in accordance with both the Plans and the required Specifications.

7.21.2 The Record Drawings shall be reflective of the actual details of the installation and include plan views descriptive of all fittings, valves, and appurtenances placed in the pipelines. This can usually be accomplished on a revised set of the original construction Plans. The Record Drawings shall be professionally drafted, and delivered on reproducible media, to a scale of not less than 1 inch = 50 feet. Linear pipeline dimensions shall be indicated for all piping branches, valves, appurtenances, or changes in size along the pipeline, from verifiable points of reference. Differing materials used shall be indicated. Changes in elevation information shall be recorded where such differs from typical installation details, such as recording significant changes in depth of cover.